

*Research Article*

# Smart tools and artificial intelligence for enhanced quality and safety in agriculture, fisheries, and aquaculture: A review

Kilinc I.<sup>1\*</sup>, Kilinc B.<sup>2</sup>, Takma C.<sup>3</sup>, Gevrekci Y.<sup>3</sup>

<sup>1</sup>Katip Celebi University, Fisheries Faculty, Fish Processing Technology Department, 35610 CiGli-Izmir, Turkiye

<sup>2</sup>Ege University, Fisheries Faculty, Fish Processing Technology Department, 35100 Bornova-Izmir, Turkiye

<sup>3</sup>Ege University, Agriculture Faculty, Animal Science Department, Biometry and Genetics Unit, 35100 Bornova-Izmir, Turkiye

\* Correspondence: kilincirem75@gmail.com

## Keywords

Artificial intelligence,  
Smart tools,  
Intelligent manufacturing,  
Enhanced processing traceability

## Abstract

This study investigates the transformative potential of smart tools and artificial intelligence (AI) in enhancing quality assurance and safety within the agriculture, fisheries, and aquaculture sectors. A structured analytical framework is used to evaluate key AI algorithms—Naive Bayes, Support Vector Machines (SVM), Deep Learning, Machine Learning (ML), Artificial Neural Networks (ANNs), Fuzzy Logic, and Random Forests—emphasizing their mathematical foundations and practical integration into intelligent systems. The convergence of AI with advanced technologies such as computer vision (CV), the Internet of Things (IoT), and sensor-based monitoring is identified as a catalyst for real-time decision-making, robust quality control, and improved operational efficiency across the food supply chain. In agriculture, AI-powered tools enable precision farming, early pest and disease detection, and data-driven crop health monitoring. In fisheries and aquaculture, intelligent systems support automated feeding, disease prediction, and sustainable resource utilization. This study applies a structured literature-based analysis combined with performance benchmarking from empirical studies, showcasing validated use cases and quantitative accuracy metrics across various AI applications. The integration of AI technologies significantly improves traceability, reduces post-harvest losses, and enhances food safety in complex supply networks. Reported outcomes indicate high performance, with accuracy rates exceeding 80% in areas such as pathogen prediction, food recognition, microplastic detection, aquaculture optimization, and species classification. Specific applications show notable precision in microalgae classification (97.67–97.86%), seaweed identification (93.5%), and fish freshness assessment (up to 100%). Despite these advancements, the study acknowledges ongoing challenges related to data standardization, infrastructure, and regulatory frameworks. The findings highlight the need for interdisciplinary collaboration and continuous innovation. Ultimately, the strategic adoption of AI and smart tools is essential for building resilient, secure, and sustainable food systems and also offers significant indicators for future research.

## Article info

Received: May 2025

Accepted: June 2025

Published: July 2025



Copyright: © 2023 by the authors. Licensee MDPI, Basel, Switzerland. This article is an open access article distributed under the terms and conditions of the Creative Commons Attribution (CC BY) license (<https://creativecommons.org/licenses/by/4.0/>).

## Introduction

The production output of the food industry is continuously increasing in parallel with the ever-growing consumer demand. This trend necessitates the implementation of increasingly stringent food safety standards. To ensure consumer health and safety and to guarantee efficient and value-added production processes for industrial stakeholders, effective quality control mechanisms are of paramount importance. In this context, computer vision (CV) technology is widely applied in integration with other Industry 4.0 components and process automation. The integration of CV applications into quality control processes can significantly improve supply chain management in the food industry by ensuring consistent product quality and minimizing waste (Lysova *et al.*, 2025). The surge in food demand and the growth of the global population in recent decades have accelerated the integration of artificial intelligence (AI) technologies into the food sector. The capability of AI-supported systems to assess food quality, provide control mechanisms, and perform various operations such as food classification and prediction has amplified the interest in and demand for these systems (Thapa *et al.*, 2023). Given the fundamental role of food in human life, the necessity of reducing food waste and improving food management and safety protocols is evident. The increasing prevalence and advanced infrastructure of computer networks have strengthened modern industrial and logistics systems. These networks continuously generate data from sensors, systems, smart devices, machines, and human interactions, which undergo in-

depth analysis. These developments have triggered a technological transformation leading to what is known as Artificial Intelligence (AI) (Barthwal *et al.*, 2024). AI is a scientific discipline that aims to develop intelligent systems capable of mimicking various aspects of human behavior through techniques inspired by nature. Advancements in the field of AI have contributed to the maturation of a knowledge domain known as machine learning (ML), which encompasses techniques that enable learning through experience (Nunes *et al.*, 2023). Machine learning algorithms can be utilized to: (a) extract operational human knowledge from a set of examples; (b) derive interpretable rules for classifying examples regardless of the linearity of human behavior or process; and (c) determine the degree of influence of each objective feature of the food item's human behavior or process on an expert's final decision (Goyache *et al.*, 2001). This integration significantly enhances the system's capacity to recognize food items, particularly in scenarios involving densely packed food images, thereby increasing accuracy rates (Chotwanvirat *et al.*, 2024). Products equipped with AI functionalities can perform thinking, decision-making, and social interaction tasks like human assistants. Building upon this similarity and aiming to complement established technology acceptance theories, hypotheses are being developed regarding consumers' preferences to purchase or avoid AI products and the evolution of these preferences across different consumer groups and AI product types (Frank, 2024). Indeed, numerous application areas exist where AI techniques and AI provide

significant advantages, which can be summarized as follows. AI is revolutionizing the food industry by enhancing food quality and safety, fostering innovation, and optimizing processes. This study examines the applications of AI in food science, including manufacturing, personalized nutrition, supply chain management, and sensory science. It also discusses techniques such as knowledge-based expert systems, artificial neural networks, fuzzy logic, and machine learning, highlighting their roles in predictive maintenance, waste management, quality control, and product development. The integration of AI with advanced sensors improves decision-making mechanisms and real-time monitoring capabilities in food safety and packaging processes. However, challenges such as high costs, data security concerns, ethical considerations, and transparency issues persist. AI holds the potential to deliver personalized products, enhance food security through predictive analysis of food products, advance sustainability by optimizing resource utilization, and ensure efficient distribution by promoting innovation in supply chain automation and personalized nutrition (Zatsu *et al.*, 2024). Deep learning offers a predictive edge over traditional machine learning for screening peptides with diverse biological activities, but challenges persist. Future research should focus on developing data augmentation strategies within large food-specific models and establishing a universal deep learning framework based on multiscale chemical domain properties to predict peptide-target dynamic interactions. The development of a high-throughput

screening infrastructure and more comprehensive research on AI methods for multifunctional properties, such as anti-obesity and anti-fatigue effects, are also crucial (Chang *et al.*, 2024). For instance, one study evaluated the potential of school meals co-designed with children or generated using AI and investigated parents' perceptions regarding the use of whole foods in their children's diets. Children, potentially with parental support, proposed recipes incorporating whole fruits and vegetables, and nutritionists and school cooks selected from these recommendations (Goulart *et al.*, 2025). The increasing knowledge of microbial ecology related to food product quality and safety, coupled with the inherent utility of ML algorithms for anomaly detection in various scenarios, suggests that applying microbiome data in food production systems for anomaly detection could be a valuable approach in food systems. These methods can be used to identify ingredients that deviate from their typical microbial composition, which may indicate food safety issues and food fraud (Beck *et al.*, 2024). Indeed, food adulteration is a deceptive practice aimed at misleading consumers for profit. The threat it poses to public health and food quality or nutritional value makes it a significant concern. Food sourcing and potential tampering should be carefully considered to protect consumers against fraud. Consequently, artificial intelligence (AI) represents the latest technology in food science and engineering for effectively addressing these challenges (Das *et al.*, 2025). For example, integrating advanced technologies into smart packaging systems offers a promising

avenue for effectively combating food fraud, building consumer confidence, and safeguarding the integrity of the food supply chain (Yang *et al.*, 2024).

AI also has the potential to transform the agricultural and food processing industries, with significant implications for sustainability and global food security. The integration of AI into agriculture has witnessed a substantial increase in recent years. Therefore, a comprehensive understanding of these techniques is necessary to expand their application across the agri-food supply chain (Nath *et al.*, 2024). The analysis of AI algorithms in agriculture, food science, and nutrition can lead to an intelligent farm-to-fork cycle, which can also contribute to significant advancements in scientific breakthroughs (Esmaily *et al.*, 2024). The efficient pattern recognition capabilities of AI algorithms and their rapid adaptation to new data promote innovation in data-driven decision-making and technological development. While significant progress has been made in food quality and safety testing using sensor and spectral technologies supported by AI, substantial potential remains for further development. The integration of AI with various emerging technologies enhances public health and safety by providing comprehensive and in-depth support for food quality and safety testing (Xu *et al.*, 2024). AI has become a transformative technology across various industries (Fernandes and DMello, 2025). Therefore, having comprehensive information about the latest developments in this field is essential for better understanding and future research endeavors (Thapa *et al.*,

2023). Consequently, Industry 4.0, driven by AI, IoT, computer vision, and big data, is revolutionizing manufacturing, particularly in the food sector. It enables precise, just-in-time production while enhancing food safety and quality through comprehensive data tracking across the supply chain. Standardized processes and real-time insights provided by analytics and alarm systems improve efficiency and responsiveness. With its ability to streamline operations and ensure compliance, AI approaches are rapidly becoming indispensable, and food manufacturers are at the forefront of their adoption (Kilinc, 2024).

Conventional food safety analyses exhibit certain fundamental limitations when confronted with the evolving demands and complexities of contemporary global food supply chains. These methodologies often rely on periodic sampling, laboratory analyses, and human-dependent inspection processes, which inherently introduce a reactive approach and may present constraints in the real-time detection of potential hazards (Xu *et al.*, 2024). Moreover, subjective assessments and operational errors stemming from human factors can compromise the consistency of food safety standards (Lysova *et al.*, 2025). The dynamic nature of increasing production volumes and consumer demands necessitates the adoption of more agile, high-accuracy, and continuous monitoring systems. In this context, artificial intelligence-based methodologies hold the potential to mitigate these structural disadvantages of traditional approaches and offer significant advancements in the realm of food safety

(Kilinc, 2024; Das *et al.*, 2025). In this context, the study examines how the strategic utilization of artificial intelligence and smart technologies within the agriculture, fisheries, and aquaculture sectors, by proven high accuracy rates, optimizes quality assurance and safety, thereby making critical contributions to the development of sustainable and secure food systems and offering a comprehensive proposal for future research.

#### *AI integrated systems' materials and methods*

AI algorithms such as Naive Bayes, Support Vector Machines, Deep Learning, Machine Learning, Artificial Neural Network, Fuzzy Logic and Random Forests etc. which are used in various studies (Kılınç *et al.*, 2022a; Kılınç *et al.*, 2022b; Kılınç *et al.*, 2023a; Kılınç *et al.*, 2023b; Kılınç *et al.*, 2024a; Kılınç *et al.*, 2024b; Mohseni and Ghorbani, 2024). Recent studies are based on the supervised use of machine learning models. For example, the most widely used models for predicting the presence of a foodborne pathogenic microorganism at any stage of the production chain include Random Forest and support vector machines with rating metrics for accuracy and precision >80% (Medina *et al.*, 2023). These models are explained in detail below.

#### *Naive bayes*

Naive Bayes (NB) is one of the widely used data mining algorithms for classification (Wu *et al.*, 2008). Based on the assumption that all attributes belonging to a given class are independent of each other, it reveals the probability that a new example belongs to a

class (Duda and Hart, 1973). The NB algorithm is based on the conditional probability concept of Bayes' theorem and is widely used in classification problems. It uses the concepts of conditional probability to calculate the probability of a particular class given the input information (Pajila *et al.*, 2023). This approach offers effective results, especially in applications such as text classification, spam detection, and document categorization.

According to Bayes theorem, for any class C and observed feature vector  $X = \{x_1, x_2, \dots, x_n\}$ , the following relation holds in (Eq.1):

$$P(C|X) = \frac{P(X|C)P(C)}{P(X)} \quad (1)$$

Here,  $P(C|X)$ : The posterior probability of class C when the features are considered,  $P(X|C)$ : The probability of observing features under class C,  $P(C)$ : A priori distance of the class, and  $P(X)$ : Marginal probability of the observed feature vector.

The reason the Naive Bayes algorithm is called "naive" is that it assumes that all features are conditionally independent of each other. Under this assumption,  $P(X|C)$  is decomposed multiplicatively as follows in (Eq.2):

$$P(X|C) = \prod_{i=1}^n P(x_i|C) \quad (2)$$

In this case, the classification decision is made by selecting the class that gives the highest posterior probability. The decision rule is expressed as follows in (Eq.3):

$$\hat{C} = \operatorname{argmax}_c P(C) \prod_{i=1}^n P(x_i|C) \quad (3)$$

This mathematical structure forms the form of the Naive Bayes algorithm and is based on the calculation of  $P(C)$  for each class and  $P(x_i|C)$  for each feature. NB classification techniques perform classification using Bayes' theorem and the independence

property. NB has many variations to adapt to various data features and improve classification performance (Pajila *et al.*, 2023).

The most common NB variations are:

- A. Gaussian Naive Bayes: This method assumes that features with continuous distribution are normally distributed. The method using feature probability training data is applied to continuous data (Subramanian and Prabha, 2022).
- B. Multinomial Naive Bayes: In the method used to classify texts according to word frequencies, the probabilities of the features are modeled using multinomial distribution parameters (Pane *et al.*, 2018).

C. Bernoulli Naive Bayes: It is typically used in text classification tasks to represent words in a document. Assigns a probability to each feature in each class (Pajila *et al.*, 2023).

D. Hybrid Naive Bayes: Hybrid Naive Bayes improve categorization with other machine learning methods. Trait selection with decision trees or support vector machines, ensemble, or hybridization can be utilized (Pajila *et al.*, 2023). The algorithm of Naive Bayes as a classification is given in Figure 1.

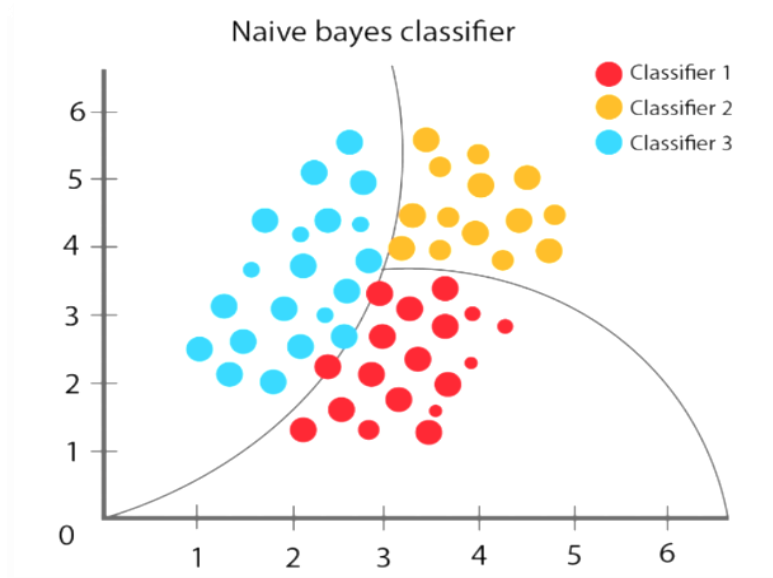

Figure 1: Naive Bayes algorithm (Widyawati *et al.*, 2023).

### Support vector machines

Support Vector Machines (SVM) is one of the machine learning algorithms developed by Vapnik and other researchers (Vapnik, 1995, Cortes and Vapnik, 1995, Vapnik *et al.*, 1997). Developed to interpret sensor data, SVM contains a two-layer structure.

SVM is used to best separate two data classes. For this purpose, decision boundaries or hyperplanes are determined. Developed to interpret sensor data, SVM contains a two-layer structure. SVM is used to best separate two data classes. For this

purpose, decision boundaries or hyperplanes are determined.

Classification is performed with the most appropriate decision boundary or hyperplane determined (Demirci, 2019). The ability to obtain the optimal separation line even in high-dimensional spaces is among the reasons why SVM is preferred. The use of kernel functions provides effective classification for data sets that cannot be separated linearly (Singh *et al.*, 2009).

The mathematical model used in the SVM algorithm is given below in (Eq.4) by (Cortes and Vapnik, 1995):

$$f(x) = \text{sign}(\sum_{i=1}^n \alpha_i y_i K(x_i, x) + b) \quad (4)$$

Where,  $\alpha_i y_i$ : Lagrange multipliers,  $y_i$ : Class labels,  $K(x_i, x)$ : Kernel function (e.g., linear, polynomial, RBF), and  $b$ : Bias term.

The graphical representation of support vector machines is given in Figure 2. In Figure 2, the two groups are not linearly separated in the left diagram. In the right diagram, the sharp line in the middle represents the hyperplane (OSH) learned by SVM and plays a critical role in the classification of the data. The data points closest to the decision boundary are determined as support vectors and these points form the margin boundaries.

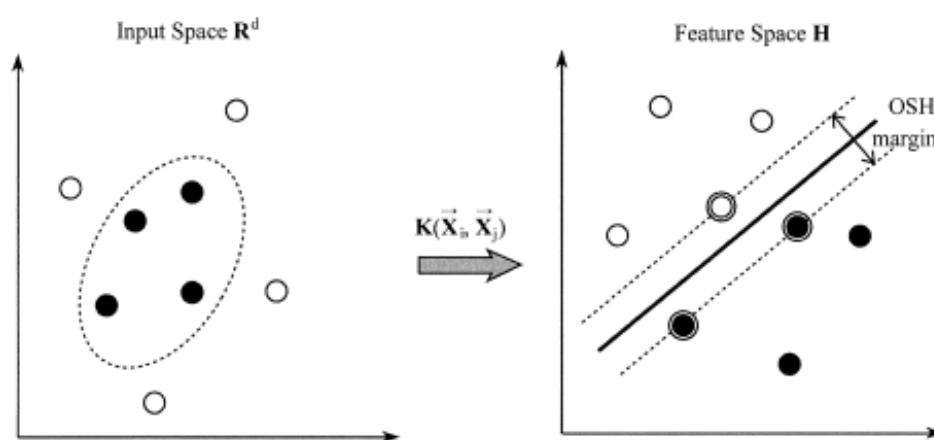

Figure 2: Support Vector algorithm (Hua and Sun, 2001).

### Deep learning

Deep Learning (DL) is a technique that can automatically extract features from data using multilayer artificial neural networks. The basis of DL algorithms was first put forward in the article published by Geoffrey Hinton and Ruslan Salakhutdinov in 2006 (Hinton *et al.*, 2016), and various DL learning algorithms emerged in the following years (Goodfellow *et al.*, 2016). In DL, which uses multiple layers of

nonlinear processing units, each successive layer takes the output of the previous layer as input (Deng and Yu, 2014). Algorithms are in the form of supervised (such as classification) or unsupervised (such as pattern analysis) deep learning (Şeker *et al.*, 2017).

Classification can be done on large data sets with DL. Learning processes performed on such data sets exhibit superior performance in solving complex problems such as

image, audio and natural language processing. The hierarchical structure between the layers increases the learning capacity of the model by providing the creation of abstract representations of the data. DL algorithms are based on an artificial neural network architecture consisting of multiple hidden layers. In DL, the first two layers represent the input layer, and the last layer represents the classification layer. The operations in the intermediate layer between the input layer and the last layer include convolution, maxpooling, dropout, normalization, Relu, Softmaxlayer, and Fullconnectedlayer layers (Schmidhuber, 2015; Guo *et al.*, 2016).

The basis of DL, which is a multilayer version of artificial neural networks, is feedforward neural networks and backpropagation algorithm. The equations of the functions used are given below equations (Goodfellow *et al.*, 2016):

*Activation Function (e.g. ReLU):*

$$f(x) = \max(0, x) \quad (5)$$

*Loss Function (e.g. Cross-Entropy):*

$$L(y, \hat{y}) = -\sum_{i=1}^n y_i \log(\hat{y}_i) \quad (6)$$

*Backpropagation:*

$$\frac{\partial L}{\partial w} = \frac{\partial L}{\partial \hat{y}} \frac{\partial \hat{y}}{\partial w} \quad (7)$$

The graphical representation of Deep Learning is given in Figure 3. According to Figure 3, while only a single hidden layer is processed with traditional neural networks (Figure 3, left side), with deep learning, the input data is passed through multiple hidden layers in its structure (Figure 3, right side). This structure is based on the principle of processing data through feedforward between layers (Xing and Du, 2018).

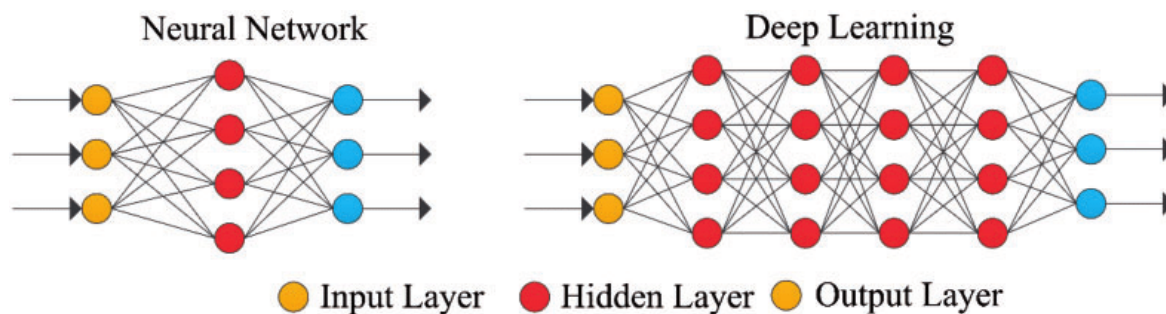

Figure 3: Deep Learning algorithm (Xing and Du, 2018).

The input data  $x$  in Figure 3 is taken from the first layer and the following transformation is applied to each hidden layer:

$$a^l = f(W^l a^{(l-1)} + b^{(l)}), l=1, 2, \dots, L \quad (8)$$

Where,  $a^{(0)} = x$ ,  $W^{(l)}$  is a weight matrix,  $b^{(l)}$  is a bias vector and  $f(\cdot)$  is an activation function.

In the last layer, the output layer  $y$  is obtained as follows:

$$y = g(W^{(L+1)} a^{(L)} + b^{(L+1)}) \quad (9)$$

Where,  $g(\cdot)$  is the appropriate activation function, which is usually chosen according to the task type.

### *Machine learning*

ML is a branch of AI that allows computers to automatically learn from data. While rules are determined by humans to solve problems in traditional programming, these rules are automatically derived from data in machine learning (Mitchell, 1997). In this way, computers can solve complex problems, make predictions, and make decisions. Machine learning is widely used in many areas such as healthcare, finance, e-commerce, autonomous vehicles, and natural language processing. Machine learning is divided into three main categories: supervised learning, unsupervised learning, and reinforcement learning.

### *Supervised learning*

Supervised learning works on labeled data sets. In this method, the correct output (label) for each data point is known. The model learns from this labeled data and makes predictions for new data. Supervised learning is used in two types of problems: classification and regression. In classification problems, the model divides the input data into predefined categories. In regression problems, the model predicts a continuous output value (Hastie *et al.*, 2009).

### *Unsupervised learning*

Unsupervised learning works on unlabeled data sets. In this method, the model tries to discover the structure or patterns in the data. Unsupervised learning is mainly used in problems such as clustering and dimensionality reduction. Clustering is used to group data points with similar properties. Dimensionality reduction is

used to visualize or facilitate the processing of data by reducing high-dimensional data to a lower-dimensional space (Bishop, 2006).

### *Reinforcement learning*

Reinforcement learning uses reward and punishment mechanisms to learn the best behavior in an environment. In this method, the model learns what to do in a certain situation by trying. Reinforcement learning is especially used in areas such as gaming and robot control (Sutton and Barto, 2018).

Machine learning processes usually consist of a series of steps. The first step is to collect data. After the data is collected, the data preprocessing step is started. In this step, missing data is filled, categorical data is digitized, and the data is normalized. Then, an appropriate machine learning algorithm is selected according to the type of problem. Many algorithms can be used at this stage. For example, if a linear regression is selected, the following model is used:

$$y = \beta_0 + \beta_1x_1 + \beta_2x_2 + \dots + \beta_nx_n + \varepsilon \quad (10)$$

$y$ : Predicted value,  $\beta_0$ : Bias term,  $\beta_1, \beta_2, + \dots + \beta_n$ : Weights, and  $\varepsilon$ : Error term. After selecting the model, the model is trained using the dataset. During training, the model learns patterns in the data. After the model is trained, its performance is evaluated on the test data. This evaluation is done using metrics such as accuracy, precision, recall, and F1-score. If the performance of the model is not sufficient, the model is improved using methods such as hyperparameter optimization and model tuning. Finally, the trained model is used to solve real-world problems.

### Artificial neural networks

Artificial neural networks (ANNs) are a model inspired by the working principle of the human brain and form the basis of machine learning and deep learning. This model consists of interconnected artificial neurons and is effective in solving complex, non-linear problems (Haykin, 1999). Artificial neural networks generally consist of three main layers: input layer, hidden layers, and output layer. Each neuron produces output by processing its inputs with a weighted sum and an activation function as given below.

$$y = f(\sum_{i=1}^n w_i x_i + b) \quad (11)$$

where,  $w_i$ : Weights,  $x_i$ : Inputs,  $b$ : Bias term,  $f$ : Activation function (e.g. sigmoid, ReLU).

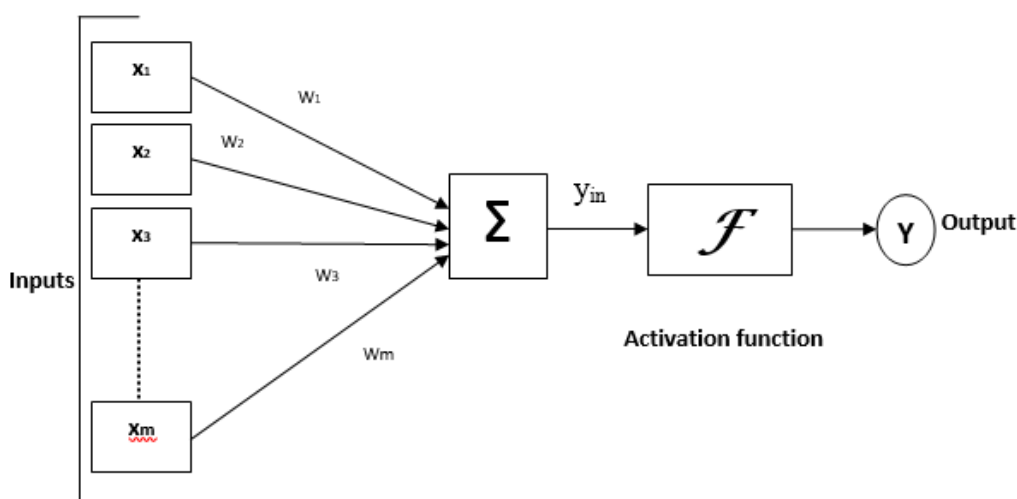

Figure 4: The ANN model used in food systems.

### Fuzzy logic

Fuzzy logic is a mathematical model used to process uncertain or ambiguous information. Unlike classical binary logic (true/false, 1/0), fuzzy logic also accepts intermediate values. In this way, it becomes possible to model uncertainties and vagueness in the real world. Fuzzy logic is widely used especially in control systems,

Artificial neural networks are trained with the backpropagation algorithm. This process updates the weights to minimize the errors of the model. The following steps are followed.

1. Forward Propagation: Input data is transmitted through the network and output is produced.
2. Error Calculation: The error between the true value and the prediction is calculated with the loss function (e.g. MSE).
3. Backpropagation: The error is propagated back through the network and the weights are updated (Goodfellow *et al.*, 2016) (Fig. 4).

decision-making, and artificial intelligence applications (Zadeh, 1965). The basis of fuzzy logic is fuzzy sets. In classical sets, an element either belongs to the set or does not. However, in fuzzy sets, an element can belong to the set to a certain degree. This degree is expressed by the membership membership function. For example, the degree to which a person is "tall" can take a

value between 0 and 1. Membership functions can usually be Gaussian, triangular or trapezoidal. Fuzzy logic is used to model uncertain situations. It is based on membership functions and rules. For example, the Gaussian membership function is expressed as follows:

$$\mu(x) = e^{-\frac{(x-c)^2}{2\sigma^2}} \quad (12)$$

$c$ : Center,  $\sigma$ : Represents standard deviation (Ross, 2010).

Fuzzy logic systems work using fuzzy rules. These rules are expressed as "If ... then ..." For example, "If the temperature is high, the fan speed increases." These rules are used in the fuzzy inference process. Fuzzy inference produces output by processing input values according to fuzzy rules. Then, these fuzzy outputs are converted to a precise value by defuzzification. For example, the average center of gravity (centroid) method is a frequently used method for defuzzification. Fuzzy logic is successfully applied in many areas. It is widely used especially in control systems (air conditioning control, automatic transmission systems), decision-making processes (medical diagnosis, financial analysis), and artificial intelligence applications (fuzzy expert systems, fuzzy neural networks). Fuzzy logic offers a flexible framework for modeling uncertainties and fuzziness and with this feature, produces effective solutions to real-world problems.

#### *Random forests*

Random forests are an ensemble method used to solve classification and regression problems in machine learning. This method creates multiple decision trees and

combines the predictions of these trees to obtain more accurate and stable results. Random forests are especially effective in high-dimensional data sets and complex problems. The basis of random forests is the bagging (bootstrap aggregating) method. Bagging creates multiple models by taking random samples from the data set and combining the predictions of these models. Random forests apply the bagging method to decision trees. Each decision tree is trained using randomly selected samples and features from the data set. In this way, each tree learns from a different perspective and the generalization ability of the model increases (Breiman, 2001).

In the training process of random forests, splitting criteria such as the Gini index or entropy are used for each decision tree. The Gini index measures impurity at a node and guides tree-splitting decisions.

The Gini index is calculated as follows:

$$Gini = 1 - \sum_{i=1}^n p_i^2 \quad (13)$$

$p_i^2$ : Proportion of class  $i$ .

Where,  $p_i$  represents the proportion of a class in a node. The lower the Gini index, the purer (homogeneous) the node is (Hastie *et al.*, 2009). One of the most important advantages of random forests is that they prevent overfitting. By combining the predictions of multiple decision trees, the generalization ability of the model increases and the risk of overfitting on the training data is reduced. In addition, random forests are robust against missing data and outliers (Breiman, 2001).

Random forests are successfully applied in many areas. They are widely used in areas such as bioinformatics, finance, image processing, and medical diagnosis. For

example, random forests are preferred to analyze patient data for cancer diagnosis or to make risk assessments in financial markets. This method offers high accuracy rates in both classification and regression problems (Hastie *et al.*, 2009). Random forests are a powerful ensemble method that combines the predictions of multiple decision trees. Thanks to the bagging method and random feature selection, it

exhibits effective performance on high-dimensional datasets and complex problems. Preventing over-learning and being robust to missing data have made random forests popular in many application areas. Consequently, Table 1 explains the AI algorithms for quality and safety in agriculture, fisheries, and aquaculture.

**Table 1: AI Algorithms for Quality and Safety in Agriculture, Fisheries, and Aquaculture.**

Algorithm	Mathematical Principle / Key Formula	Application areas	Accuracy (%)	Advantages	References
Naive Bayes (NB)	Bayes' Theorem: $P(C \setminus X) = \frac{P(X \setminus C)P(C)}{P(X)}$ Classification Rule: $\hat{C} = \operatorname{argmax}_c P(C) \prod_{i=1}^n P(x_i   C)$	Foodborne pathogen prediction; food quality classification (e.g., milk, grain)	84–89%	Fast, efficient on small datasets; handles high-dimensional inputs well	Pajila <i>et al.</i> , 2023; Kılınc <i>et al.</i> , 2024a
Support Vector Machines (SVM)	$f(x) = \operatorname{sign} \left( \sum_{i=1}^n \alpha_i y_i K(x_i, x) + b \right)$	Fish species classification; food safety prediction; microbial detection	88–92%	Excellent for non-linear, high-dimensional problems; effective with kernel tricks High accuracy; automatic feature extraction; ideal for image/audio data	Cortes and Vapnik, 1995; Medina <i>et al.</i> , 2023
Deep Learning (DL)	Activation Function: $f(x) = \max(0, x)$ Loss: $L(y, \hat{y}) = -\sum_{i=1}^n y_i \log(\hat{y}_i)$ Backpropagation: $\frac{\partial L}{\partial w} = \frac{\partial L}{\partial \hat{y}} \frac{\partial \hat{y}}{\partial w}$	Fish freshness detection, microplastic analysis, aquaculture monitoring	96–100%	Versatile; applicable to classification and regression; scalable Models	Xing and Du, 2018; Kılınc <i>et al.</i> , 2023a
Machine Learning (ML)	$y = \beta_0 + \beta_1 x_1 + \beta_2 x_2 + \dots + \beta_n x_n + \varepsilon$	Yield prediction, risk assessment, fish mortality forecasting	85–95%	complex, non-linear relationships; adaptive learning Handles uncertainty; ideal for vague or fuzzy environments Robust to missing data; prevents overfitting; suitable for complex datasets	Mitchell, 1997; Kılınc <i>et al.</i> , 2022a
Artificial Neural Networks (ANN)	$y = f \left( \sum_{i=1}^n w_i x_i + b \right)$	Aquaculture automation; spoilage prediction; fish disease monitoring	91–99%		Haykin, 1999; Goodfellow <i>et al.</i> , 2016
Fuzzy Logic	Gaussian Membership Function: $\mu(x) = e^{-\frac{(x-c)^2}{2\sigma^2}}$	pH/temperature control in aquaculture; fruit ripeness grading	87–95%		Zadeh, 1965; Ross, 2010
Random Forests (RF)	Gini Index: $Gini = 1 - \sum_{i=1}^n p_i^2$	Microalgae/seaweed classification; food fraud detection; aquaculture optimization	93–97%		Breiman, 2001; Kılınc <i>et al.</i> , 2023b

### Artificial intelligence in industrial usage

In contemporary society, the application of AI for automatic food recognition offers an important potential for nutrition monitoring

in food production and consumption scenarios, reducing food waste and increasing productivity. The latest technologies such as Computer Vision and

Deep Learning are extremely useful, allowing machines to learn automatically, thereby facilitating automatic visual recognition. Despite some research in this area, the challenge of achieving accurate automatic food recognition quickly remains a significant research gap. Some models have been developed and implemented, but quickly maintaining high performance with low computational cost and low access to expensive hardware accelerators is an area that still needs further research and improvement (Rokhva *et al.*, 2024). AI can make the best use of the existing agricultural and food supply chain system to overcome the challenges of nutritional demand, resource depletion, population growth, climate change, and pollution (Sharma *et al.*, 2022). In recent years, (AI)-driven machine learning methods have shown excellent performance in the analysis of microplastics (MPs) in soil and water (Hu *et al.*, 2024).

#### *Aquaculture, fisheries, and agriculture*

The aquaculture and fishing sectors are finding ingenious ways to grow and meet the growing human demand for nutrient-rich fish and seafood by efficiently using the vast water resources and biodiversity of the world's aquatic life. This includes the gradual integration of information technology, data science, and AI with fishing and fish farming methods to ensure the intensification of aquaculture production, the sustainable use of natural fishing resources, and the mechanization-automation of allied activities. Special data mining and machine learning systems are being developed to process complex data sets and perform intelligent tasks such as

analyzing cause-and-effect relationships, predicting problems, and providing intelligent precision solutions for farming and catching fish (Gladju *et al.*, 2022). AI is a family of systems that allows computers to simulate human behavior, such as learning from experience and recognizing visual patterns. This primer explains how AI has been used to track and monitor fishing vessels from space, shore, and seabed, and then applied to process this information to achieve fisheries management goals such as combating illegal fishing. The exponential rise of AI in fishing applications over the past decade has been showing no signs of slowing down. As the authors have considered how tomorrow's AI could improve the sustainability and transparency of fisheries, they also have emphasized the constant need for human oversight in an increasingly automated future (Welch *et al.*, 2024). Despite this, electronic monitoring (EM) has increasingly been used to monitor catch and catch in wild catch fisheries. EM video data has still been manually reviewed and added to ongoing management costs. Computer vision, machine learning, and AI-based systems have been reported to be the next step in automating EM data workflows (Khokher *et al.*, 2021). AI-based advanced tool deep learning (DL) aids in fish classification, identification, microbial infectious disease detection, behavior analysis, size or biomass estimation, and water quality estimation and has been extensively studied in smart fish farming with results of higher accuracy than traditional approaches. For this purpose, information has been provided on the use of advanced AI techniques in the aquaculture

industry, focusing on identifying fish diseases affecting fish and their characteristics, microbial pathogen detection, and diagnosis (Choudhary *et al.*, 2025). One study provided a new multi-purpose optimization approach by integrating the Experimental Design (DOE) method with the Adaptive Artificial Multiple Intelligence System (AAMIS) to optimize aquaculture parameters. The Taguchi DOE method efficiently designed experiments by selecting the basic variables and their levels. Multipurpose regression models developed using statistical software and fine-tuned by AAMIS, balance maximizing efficiency by minimizing costs (Sriprateep *et al.*, 2025). Similarly, the other article focused on designing a Digital twin infrastructure that supported the agile-based AI Internet of Things (IoT) system for smart fish farming in aquaculture. Their infrastructure included the IoT, cloud technology, and AI as building blocks. Each digital twin service was equipped with multiple AI services (or digital twin objects) that could perform complex and other functions, such as optimizations, forecasts, and analysis for intelligent decision-making to optimize farm profits and production (Ubina *et al.*, 2023).

AI tools such as machine learning, cameras, algorithms, and the internet of things (IoT) provide solutions for reducing human intervention, increasing productivity and monitoring fish health, feed optimization, and water resource management. However, challenges such as data collection, standardization, model accuracy, interpretability and integration with existing aquaculture systems remain (Rather *et al.*, 2024). Recent advances in

biotechnological processes are also increasingly relying on machine learning (ML) to improve efficiency in optimizing microalgae cultivation, especially by using food waste as an alternative culture medium. For example, the correlation between ML model predictions and the dry cell weight of this microalgae was analyzed (Ramandani *et al.*, 2025). The aim of another study was to classify different types of microalgae using machine learning (ML) and deep learning (DL) methods. Overall, the Azure custom vision model performed the best with the highest accuracy of 97.67% and 97.86% at the probability threshold of 50% and 80%, respectively. This study aimed to connect AI technologies to microalgae based on rapid and sensitive microalgae classification, as well as understanding the shape, texture, and convolution properties that could accelerate the development of real-time monitoring (Chong *et al.*, 2024). In another study, in particular, YOLOv8 and YOLOv5 have been used as basic transfer learning models. By uploading various pre-trained weight files, this study was able to automatically classify *Porphyra haitanensis* into four categories according to the harvest period and simultaneously detect four types of common impurities in it. Among the tested models, YOLOv8n-cls achieved the best balance in classifying the harvest period with the highest accuracy of 93.5%. This represented a significant improvement of 16% compared to performance without transfer learning (Gao *et al.*, 2024).

The non-stop evolution of analytical instrumentation determines an exponential increase in data production, which

increases the new cutting-edge analytical challenges that require the gradual integration of AI algorithms into instrumental data processing software. Machine learning, deep learning, and computer vision are the most common techniques adopted to take advantage of the information potential of advanced analytical chemistry measures (Caratti *et al.*, 2024). Biochemical detection plays a vital role in life and natural sciences research. However, with the increasing environmental complexity and sample quantity, traditional sensors cannot meet the need for accurate and efficient analysis of a large amount of data. The emergence of AI provides a new strategy for overcoming the challenges in biochemical sensing, especially in the field of molecular diagnostics and imaging analysis (Li *et al.*, 2024). The development of artificial intelligence to model wastewater heavy metal detection and removal has also been studied (Bhagat *et al.*, 2020).

The application of AI in the entire food production ecosystem from crop production, food waste management, animal husbandry, harvest/slaughter, post-harvest management, food processing, food distribution, and food consumption has been evaluated (Kutyauripo *et al.*, 2023). Food biochemistry, which is the study of chemical processes and compounds occurring in foods, plays a very important role in determining the safety, quality, and nutritional value of foods. With the growing interest in food safety and personalized nutrition, the integration of computer science, especially ML and AI into food biochemistry has been gaining momentum (Amore and Philip, 2023). For

example, AI has been making rapid progress over the past few years and is becoming an important tool for addressing the impacts and challenges of an aging population. Therefore, one research introduced population aging and AI into agricultural production by focusing on the effects of population aging on food security and the function played by AI in it (Lee *et al.*, 2024).

#### *Monitoring special characteristics of food products according to the processing conditions*

The fourth industrial revolution (Industry 4.0) is leading to significant changes in many sectors, including the food industry. This study examines, among others, how Industry 4.0 technologies such as artificial intelligence, robotics, blockchain, and smart sensors are transforming unit operations in the food sector. These processes, which include preparation, processing/ conversion, preservation/stabilization packaging and transportation, are very important for the transformation of raw materials into high-quality food products. Industry 4.0 technologies combine advanced digital, physical, and biological innovations to increase precision, productivity, and environmental responsibility in food production (Hassoun *et al.*, 2024). With the advancement of global intelligence and the increasing awareness of sustainable development, artificial intelligence technology is increasingly being applied to the food industry (Zhao *et al.*, 2025). The processed food industry is primarily concerned with processing techniques, food quality, and nutrient content, as customers

expect consistent food products in terms of flavor, texture, sensory characteristics, and shelf life. Due to the increasing need for food and the growing global population, AI has become a modern technology in the food industry over the past few decades. The demand for AI-based technology in the processed food industry is based on forecasting, food classification, control tools, food quality assessment, etc. (Jadhav *et al.*, 2025). For example, porosity is a related property of dried products and depends on various parameters such as food material properties, drying technologies, and process conditions. The multifaceted interactions between these parameters make the mathematical modeling of porosity a difficult task. In recent years, Artificial Intelligence (AI) tools are effective in identifying complex and nonlinear problems in many fields. The developed models can be used as quick and simple tools for estimating the porosity of anhydrous products and therefore help to design and optimize drying processes (Thibault *et al.*, 2024). Furthermore, AI improves food biotechnology by supporting food enzyme engineering, microbial metabolic engineering, food safety, and food microbiology in general. The use of AI tools in the food industry ranges from food processing to food quality and safety, including all aspects of the production of foodstuffs (Amore and Philip, 2023). Additionally, AI improves the efficiency of collagen extraction by optimizing parameters such as enzyme concentrations, temperature, and pH, leading to higher yield and better quality (Srinivasan *et al.*, 2025). Ultimately, AI technologies, including machine learning and data

analytics, are revolutionizing areas such as food microbiology, biotechnology, quality assessment, and safety monitoring. AI improves, improves microbial risk assessments by leveraging large datasets efficiency and facilitation of fermentation processes predictive modeling for food quality and shelf life. However, the integration of AI into these areas is not without obstacles. Challenges include data privacy concerns, the need for standardization in AI methodologies, and the need for interdisciplinary collaboration between food scientists and data scientists. In addition, the accessibility of AI tools for smaller food businesses remains a significant obstacle (Almoselhy and Usmani, 2024). Despite this obstacle, the prepared food sector has grown rapidly in recent years due to the fast pace of modern life and the increasing consumer demand for convenience. Prepared foods are playing an increasingly important role in the modern catering industry due to their ease of storage, transportation, and operation. However, their processing faces various challenges, such as labor shortages, inefficient sorting, inadequate cleaning, unsafe cutting operations, and lack of industry standards. The development of artificial intelligence (AI) will change the processing of prepared foods (Huang *et al.*, 2025).

#### *Predictive microbiology and monitoring of harmful microorganisms*

The integration of AI into microbiology has transformative potential to advance our understanding and treatment of microbial systems (Mohseni and Ghorbani, 2024). Unsafe foods containing harmful bacteria,

viruses, parasites, or chemicals can cause more than 200 different diseases, from diarrhea to cancer. Worldwide, an estimated 600 million (about 1 in 10 people) get sick every year after eating contaminated food, resulting in 420,000 deaths and the loss of 33 million years of healthy life. Therefore, it is necessary to identify and respond to public health threats associated with unsafe foods with enabling technologies or tools (Medina *et al.*, 2023). AI has emerged as a powerful new tool in the diagnosis and treatment of bacterial infections. Artificial intelligence is rapidly revolutionizing the epidemiological study of infectious diseases, enabling effective early warning, prevention, and control of epidemics. Machine learning models provide a highly flexible way to simulate and predict the complex mechanisms of pathogen-host interactions, which is crucial for comprehensively understanding the nature of diseases (Zhang *et al.*, 2024). Some publications in this field have demonstrated the role of metabolomic biomarkers, fingerprints, and profiles in the identification and early detection of microbial risks. The workflow for screening and verification of biomarkers of pathogenic microorganisms in food matrices is currently underway. The integration of AI and metabolomic profiling points to high potential in real-time monitoring and identification of microbial hazards at various stages of food production, transportation, and consumption (Feng *et al.*, 2024). Predictive microbiology is related to the prevention, control, or limiting of the presence of microorganisms by mapping their potential response to certain environmental

conditions such as temperature, pH, nutrients (protein and fat), water activity (aw), and others. Machine learning, as a branch of artificial intelligence, learns from this data by determining patterns of decision-making (Medina *et al.*, 2023). For example, the presence of *Vibrio parahaemolyticus* (Vp) at different stages of the production of seafood has had negative effects on both public health and the sustainability of the industry. Powerful data mining tools in the field of machine learning and artificial intelligence, which can make better use of omics data and solve complex problems in the processing, analysis, and interpretation of omics data, can further improve our mechanical understanding of VP (Liu *et al.*, 2024).

There are also numerous reports on the effect of co-culturing lactic acid bacteria (LAB) and yeast on the quality of fermented foods. The interactions between the LAB and yeast affect the flavor, texture, and even the safety of fermented foods. Many types of research have been supported by the analysis of the interaction between lactic acid bacteria and yeast. Bioinformatics tools have deciphered the metabolic connections between various species. So, AI or ML-based approaches have been used and are also more accurate in predicting strain properties (Yuan *et al.*, 2025). Antibiotic-resistant bacteria pose significant risks to global health, especially through transmission in the food chain. For this reason, the authors developed an AI-driven quantification of antibiotic-resistant bacteria in food using a color-coded multiplex hydrogel digital loop-mediated isothermal amplification (LAMP) system. After amplification, red, green, and blue,

fluorescent dots appeared on the hydrogels, which were automatically identified and quantified using a deep-learning model. Carbapenem-resistant *Escherichia* and methicillin-resistant *Staphylococcus aureus* were also successfully detected in real fruit and vegetable samples (Yang *et al.*, 2025). The application of AI has continued to show promise in microbiome data analysis and may offer more opportunities for downstream analytical automation to help food safety and quality (Beck *et al.*, 2025). However, predictive microbiology presents some challenges that have yet to be overcome. The first challenge involves the complexity of cell physiology; very little is known about how it responds to various external biochemical and environmental conditions. Secondly, its characteristics of high biological variability should be considered. Moreover, the accuracy of the data in deposition techniques is poor, largely because direct plate counting- the standard numbering method -provides a very low degree of accuracy (Martinez *et al.*, 2005).

#### *The freshness, processing, and quality of fish and marine products*

In one study, convolutional Neural Network (CNN), Dense Network 121, Inception V3, and ResNet 50 machine learning algorithms were used to determine the quality changes in bream stored under refrigerator conditions using eye and gill images. Sea bream was divided into 3 different freshness categories fresh, medium, and spoiled, and analyzed with machine learning algorithms. According to the confusion matrix values, it was calculated that the prediction performance

of the model in the eye parameter was 100% and the lowest value in the spoiled class was 98.42%. The study concluded that CNN and DenseNet 121, developed in conjunction with Grad-CAM and LIME, were indicated as a non-destructive method that could be used to determine the freshness of sea bream under refrigerator conditions (Genç *et al.*, 2025). To ensure non-destructive and rapid detection of oyster freshness, a smart method using deep learning fused with knowledge of malondialdehyde (MDA) and total sulfhydryl groups (SH) was proposed. In addition, the interpretability of the two models for the image of oyster meat was also investigated using feature visualization and the most powerful activation techniques. Therefore, this study brought new thoughts on oyster freshness prediction in terms of computer vision and AI (Lu *et al.*, 2023). The results of another study showed that the dataset was effective in successfully determining the freshness of the fish. The results were impressive as a total of 4476 images of fresh and stale fish were used in the proposed model. Various machine learning models (k-NN, SVM, LR, RF, and ANN) were used for each of the algorithms (SqueezeNet and InceptionV3). In short, the data set extracted its characteristics separately with the specified deep learning, and the results were individually trained by machine learning. Machine learning models achieved high accuracy rates ranging from 99.6% to 100% to assess the freshness of fish using SqueezeNet and Inception V3 feature extraction. The results showed the effectiveness of the approach in objectively determining fish freshness (Yasin *et al.*,

2023). The freshness classification method of the yellow croaker (*Larimichthys crocea*) was developed based on the computer vision technique and a convolutional neural network (CNN). A modified Res NeXt architecture was implemented to automatically extract features and create a freshness classification model. The CNN model was able to identify imperceptible visual changes and achieved classification accuracy of 72.0% and 84.0% at 12 and 24-hour intervals, respectively. In summary, this method was reported to be cost-effective, non-destructive, and real-time evaluation of environmentally friendly fish freshness, especially in the early stages of storage (Zheng *et al.*, 2025). In another study, to provide high-quality data for ML applications for the identification and classification of different varieties of dried fish, the dataset contained a variety of images for each category individually and collectively. The dataset used standardized lighting, background, and object exposure for optimal ML performance. This rich dataset empowered researchers and data scientists to leverage ML for various applications in the Indian dried fish industry. In general, the Dried Fish Dataset for Indian Seafood aimed to take advantage of ML to improve the standardization, quality control, safety, and efficiency of the Indian dried fish industry (Paygude *et al.*, 2024).

#### *Food quality and safety*

AI and other such advanced technologies have penetrated many aspects of the food chain over the years, covering both farm-to-fork or ocean-to-fork production as well as

food quality and safety testing and forecasting (Karanth *et al.*, 2023). Although the number of AI-related studies has been increasing, the number of publications related to AI and sensory studies has been reported to be low. AI is becoming vital for sensory and consumer science thanks to its ability to efficiently explore and correlate data from instrumental and human testing to produce solutions that benefit the food industry, especially consumers (Nunes *et al.*, 2023). Furthermore, AI applications have increasingly been adopted in food supply chains (Manning *et al.*, 2022). These techniques have evolved into practical, fast, and effective tools along with detection devices for quality assessment, especially in the detection of falsifications and deficiencies in the food industry (Othman *et al.*, 2023). For example, these developments significantly have increased seed testing and contributed to improving global food security (Singh *et al.*, 2025). AI, which is used with different data sources, is becoming a technology that can provide fast solutions in determining food quality and safety. The available data sources used for AI are defined as, for example, computer/machine vision, spectroscopy, i.e. NIR, and temperature. Different AI approaches can be applied to some food safety applications more than others. Different machines and deep learning algorithms with supporting food samples are discussed and how they potentially affect future food quality and safety (FQS) considerations (O'Shea *et al.*, 2024). FQS are important aspects of everyone's life and health. With the rapidly advancing field of analytical sciences, there is an increasing demand for intuitive,

accurate, and fast control of FQS. In recent years, AI has emerged as a major opportunity for the identification of FQS indicators, providing unique opportunities for extracting information from complex or large datasets and making decisions in areas such as chromatography, mass spectrometry, and spectroscopy (Yi *et al.*, 2024). In one study, ochratoxin A (OTA), which is prone to contaminating food products, poses a significant threat to human health. To accurately detect OTA contamination (COTA) in foods and provide timely early warnings, a new four-mode nano biosensor detection system based on mixes has been developed. The method developed in this study had certain advantages in that it could achieve level four modal OTA detection with lower detection limits, and the detection results of the four modalities could be mutually verified, thereby increasing the accuracy. It also provided new insights for designing advanced biosensors in future applications and opened new ideas for remote intelligent hazard factor detection in the food industry (Liu *et al.*, 2025). In another study, Atlantic salmon was reported to be an important aquaculture product. The problem of mixture residue in salmon could affect food safety and quality problems. Traditional methods of residue detection required the use of large or specialized instruments, so the remains needed to be detected quickly, cost-effectively, and in real-time. To solve this problem, the authors proposed a new strategy that performed well both quantitatively and qualitatively YOLOv5n-se, whereas YOLOv5n, YOLOv5s, YOLOv5m, YOLOv5l, YOLOv8n, and Faster RCNN were trained as comparison

algorithms (Feng *et al.*, 2023). Indeed, maintaining food safety standards is very important to protect public health and the economic integrity of the food industry. AI is a groundbreaking tool with great potential in the field of food safety. The integration of AI technologies into food safety applications not only improves traditional risk management methods but also encourages a more proactive approach to identifying and mitigating potential hazards. By leveraging AI capabilities, the food industry can significantly improve safety outcomes, reduce operational inefficiencies, and increase consumer confidence (Yu *et al.*, 2025). For example, smart packaging technologies are crucial in reducing food fraud through anti-tamper measures and traceability. However, independent smart packaging technologies alone cannot create comprehensive traceability within the food chain. The integration of blockchain and AI technologies can improve traceability and combat food fraud. Blockchain increases transparency, while AI enables the sensitive analysis of comprehensive datasets (Yang *et al.*, 2024). Another example can be given for microplastic contamination in food products has become a growing concern due to its potential effects on human health, the environment, and food safety. Over the past decade, microplastics have been detected in a wide range of food items, including seafood, salt, processed foods, and beverages. The research also highlighted the need for better detection methods such as multispectral imaging and AI-based algorithms to improve the accuracy and effectiveness of microplastic identification in food products (Mir *et al.*,

2025). New opportunities for future research and development on integrating machine learning and robot technologies have been discussed to facilitate future efforts to reduce microplastic pollution and advance artificial intelligence technologies (Guo *et al.*, 2024).

AI Robotics is the official term for an 'intelligent welded' robot that can work with vision (eye) to detect a product defect, or a control operating system to help the robot distinguish and reject the product during production. Several advanced manufacturing automation technologies have been developed, including automated supervision, autonomous robots, additive manufacturing, ubiquitous manufacturing, cloud manufacturing, and cyber-physical systems. It has been considered that smart and automation technologies are applicable to help employees. As knowledge-oriented industries develop in terms of AI and robotic automation, and to upgrade the current and next-generation workforce, higher and further education is needed to provide a better understanding of robotic automation in manufacturers facing endless challenges such as product innovation, high turnover workforce, labor shortages, quality issues and others (Hwa and Chuan, 2024). Eventually, the integration of AI into food safety and quality management has made a significant leap forward in ensuring the safety, quality, and traceability of food products. The food industry has improved the detection accuracy of harmful microorganisms, allergens, and chemical pollutants by taking advantage of ML and DL. These advanced AI techniques have also optimized production processes and

improved the efficiency of food quality control (Yu *et al.*, 2025).

#### *AI sensors*

AI uses data from machine vision, image processing, and sensors to monitor and predict key quality indicators in food products. By integrating AI with blockchain and IoT, limitations such as security and centralization can be mitigated, and data analysis and modeling can be improved. The application of AI supports sustainability, optimizes resource allocation, closes the knowledge gap in sales, and helps manufacturers and operators (Zhang *et al.*, 2024). For example, AI can be used in the food industry for freshness detection, pathogen detection, spoilage detection, odor detection, etc. The application of sensors for various applications has also been developed. Currently, an AI-assisted detection system called intelligent systems has been put into operation in the food industry. This fusion of technologies has a distinct potential to revolutionize the entire food industry with efficient food production, optimal food processing, and high-quality food production and preservation (Thapa *et al.*, 2023). Indeed, the interaction between AI and biosensors offers many advantages and adaptability to dynamic analytical challenges that significantly have improved food safety monitoring and potentially redefined the food safety and quality assurance environment (Moulaoum and Ghorbanizzmani, 2024). The user-friendly in-field detection protocol is crucial for the effective monitoring of the intended analytes in less developed countries or

resource-limited environments. However, current detection strategies require professional technicians and expensive laboratory-based instruments that cannot perform on-site point-of-care analyses. To solve this problem, an AI handheld sensor has been designed for direct reading of Ni<sup>2+</sup> and EDTA in food samples (Yan *et al.*, 2024).

#### *Food-dependent healthcare sectors*

The advancement of technology has continued to be an immersive interest for humanity over the past decades. Technology enterprises have introduced a stream of innovations to address universal health problems (Alhasan and Hasaneen, 2021). For example, ML allows computer systems to analyze data using algorithms that mimic human intelligence, while DL processes information through multi-layered artificial neural networks. These technologies are used in many fields such as microbiological diagnosis, drug discovery, infection control, and patient follow-up (Kandilci *et al.*, 2024). The new functional properties of peptides have opened new horizons in personalized medicine. With AI methods combined with therapeutic peptide products, pharmaceuticals, and biotechnology rapidly advance drug development and reduce costs. Short-chain peptides inhibit a wide range of pathogens and have great potential for targeting diseases. To address the challenges of synthesis and sustainability, AI methods, i.e. machine learning, need to be integrated into their production (Hashemi *et al.*, 2024). Furthermore, AI plays a vital role in planning, development, modeling,

evaluation, and optimization of product features. In recent years, machine learning algorithms integrated into artificial neural networks, neuro-fuzzy logic, and decision trees have been applied to enormous areas related to drug formulation development. Optimized formulations based on optimized properties derived from artificial intelligence Technologies were transformed from laboratories to markets (Ali and Alrobaian, 2024). For example, Food Database Meets Artificial Intelligence was reported to be a new method for personalized patient eating plans. Due to the increasing capabilities and use of AI, its use in nutritional counseling is indicated to be paramount in-patient compliance. This situation not only can be changed for patients with all medical diseases but also for nutritional needs (Assaf, 2024).

Automated and AI-enabled systems continue to be integrated into various healthcare sectors, including orthopedic shoulder surgery. As AI advances, there have been reported to be plenty of opportunities for it to be incorporated into clinical settings. This technology can be adopted for clerical tasks such as patient recruitment and planning, or for documenting and billing patient encounters. In clinical practice, AI can be used to support evidence-based decision-making, such as implant selection or providing a differential diagnosis (Shamtej *et al.*, 2025). For example, the role of industry to grow clinical AI applications in gastroenterology and endoscopy was studied (Chiang and Hong, 2025) In another study, AI was attempted to copy aspects of human intelligence into machines. Preventive cardiology, a sub-

specialist of cardiovascular (CV) medicine, aims to target and reduce known risk factors for CV disease (CVD) (Sherbini *et al.*, 2024). In the field of healthcare, many productive and non-productive AI and ML tools have been developed and deployed. At the same time, medical device manufacturers benefit from AIML. However, the adoption of AI in healthcare brings with it various concerns, including safety, security, ethical biases, accountability, trust, economic impact, and environmental impacts. Effective regulation can mitigate some of these risks, promote fairness, create standards, and advocate for more sustainable AI practices (Pantanowitz *et al.*, 2024). While AI offers significant opportunities to improve diabetes care and reduce healthcare costs, its successful implementation requires overcoming various obstacles, including regulatory barriers, and ensuring equitable access to technology. Future research should focus on developing interoperable AI systems that integrate seamlessly into existing healthcare infrastructures and meet the diverse needs of diabetic populations (Ma *et al.*, 2025). Overall, the developments herald a new era in healthcare that promises improved diagnostic precision and efficiency through digital and AI technologies, potentially improving patient care and strengthening educational and research activities (Zhang *et al.*, 2024). Despite the significant advances that AI has brought to microbiology, challenges such as data heterogeneity, model transparency, and ethical considerations must be addressed. Interdisciplinary collaboration and rigorous validation of AI models are crucial to

overcome these challenges. The future of AI in microbiology looks promising with potential applications in personalized medicine, rapid pathogen detection, and environmental monitoring. AI not only provides a powerful tool for microbiological research with the potential to revolutionize our diagnosis and treatment but also provides an understanding of microbial ecosystems (Mohseni and Ghorbani, 2024).

## Results

The integration of AI is demonstrably reshaping various dimensions of the food and agriculture sectors, offering improvements in speed, accuracy, efficiency, and sustainability. Recent studies have yielded promising empirical outcomes highlighting AI's capabilities across multiple domains:

- Vision-based deep learning models have achieved high accuracy in rapid, non-destructive analysis of food composition and nutrient profiling, outperforming traditional detection methods (Kaushal *et al.*, 2024).
- AI-based systems have enabled high-throughput scanning and analysis of foodborne bioactive peptides (FBPs), significantly reducing the time required for mechanism exploration compared to conventional experimental techniques (Chang *et al.*, 2024).
- Supply Chain 4.0 innovations, driven by AI integration, enhance traceability and reduce inefficiencies in farm-to-market pathways (Niu *et al.*, 2024; Zhang *et al.*, 2024).
- Distributed AI (DAI) systems have shown success in facilitating real-time

decision-making and optimization in complex supply networks (Sharifmousavi *et al.*, 2024).

- The combination of blockchain and AI in packaging offers considerable potential in fraud prevention within food logistics chains (Yang *et al.*, 2024).
- AI is contributing to advancements in 3D food printing materials by expediting biomaterial development, although large-scale testing is still required (Niu *et al.*, 2024).
- Integration with sustainable materials and energy-saving mechanisms highlights AI's role in supporting Industry 4.0 objectives, including cost efficiency and performance improvement (Malik *et al.*, 2024; Grira *et al.*, 2025).
- In robotics and microbial analysis, AI supports an enhanced understanding of multi-omics interactions and contributes to the development of automated sensors for rapid analyte detection (Yan *et al.*, 2024; Yuan *et al.*, 2025).
- A noteworthy sectoral application includes AI's potential for ensuring compliance and traceability in halal food systems, where authenticity and safety are paramount (Nawaz *et al.*, 2025).

## Discussion

The reported results collectively underscore the transformative influence of AI across various sectors of food production and quality assurance. Notably, the application of computer vision and deep learning techniques has not only accelerated detection times but has also increased accuracy and reduced waste. This is particularly crucial in perishable sectors like seafood, where freshness assessments

using AI-based visual analysis methods (e.g., CNNs) offer scalable and non-invasive solutions. Moreover, AI's integration into supply chain management and fraud prevention systems presents valuable opportunities for increasing transparency and operational efficiency. The ability to make autonomous, real-time decisions via DAI systems is reshaping how food logistics are executed and optimized. However, despite the computational advantages, the economic feasibility of implementing blockchain-integrated AI in small-to-medium enterprises remains a concern. From a research and development perspective, the use of AI in 3D food printing, robotics, and multi-omics analysis opens new avenues for precision food production and personalized nutrition. Yet, these innovations also introduce challenges related to algorithmic complexity, model interpretability, and the alignment between academic developments and industrial implementation needs. Crucially, as AI systems gain greater access to sensitive operational and biological data, data privacy, ethical usage, and algorithmic bias must be addressed. Pantanowitz *et al.* (2024) emphasize the importance of establishing flexible yet robust regulatory frameworks that allow innovation while safeguarding ethical considerations. In this context, Table 2 summarizes AI integration across various applications.

**Table 2: Overview of AI integration: applications, technologies, and challenges.**

Sector/ Application	Specific AI Applications and Examples	Key Technologies/ Methods	Benefits/ Outcomes	Detailed Challenges/ Research Gaps	References
Agriculture and Aquaculture	Precision farming, crop monitoring, fish health analysis, feed optimization, automated harvesting, water quality management	AI, Machine Learning, Computer Vision, IoT, Robotics, Remote Sensing, Deep Learning	Increased yield, reduced resource usage, improved animal welfare, early disease detection, optimized growth	Data collection in diverse environments, model robustness to weather and pests, integration with existing farm equipment, data privacy in agricultural settings, scalability for small farms	Choudhary <i>et al.</i> , 2025; Sriprateep <i>et al.</i> , 2025; Rather <i>et al.</i> , 2024; Ramandani <i>et al.</i> , 2025; Chong <i>et al.</i> , 2024; Gao <i>et al.</i> , 2024
Food Waste Reduction	Automated sorting of food waste, predicting food spoilage, optimizing inventory management, personalized portion control, monitoring food consumption patterns	AI, Machine Learning, Computer Vision, IoT, Predictive Analytics, Image Recognition	Reduced food waste at production and consumer levels, optimized resource utilization, lowered environmental impact, cost savings	Data availability for diverse food types, addressing consumer behavior changes, developing user-friendly waste management systems, handling mixed waste streams	Zatsu <i>et al.</i> , 2024; Beck <i>et al.</i> , 2024
Personalized Nutrition	Dietary recommendations based on individual health data, food preference analysis, meal planning, personalized supplement suggestions, real-time health monitoring	AI, Machine Learning, Data Mining, Nutrigenomics, Wearable Sensors, Mobile Apps, Recommender Systems	Improved health outcomes, personalized dietary guidance, enhanced consumer engagement, proactive disease prevention	Data privacy and security, integrating diverse health data, validating personalized recommendations, addressing ethical considerations, handling consumer acceptance	Zatsu <i>et al.</i> , 2024; Goulart <i>et al.</i> , 2025; Frank, 2024
Food Fraud Detection	Authenticity verification, origin tracking, adulteration detection, ingredient verification, supply chain monitoring, label verification	AI, Machine Learning, Blockchain, Spectroscopy, DNA Analysis, Computer Vision, Smart Packaging	Enhanced consumer trust, reduced economic loss, improved supply chain transparency, rapid detection of fraudulent activities	Developing robust detection methods for complex adulteration, ensuring data integrity in blockchain systems, addressing the cost of advanced detection technologies, handling the variability of natural products	Das <i>et al.</i> , 2025; Yang <i>et al.</i> , 2024
Sensory Science and Consumer Preferences	Predicting consumer acceptance, flavor profiling, texture analysis, automated sensory evaluation, product development optimization, consumer behavior analysis	AI, Machine Learning, Deep Learning, Sensory Data Analysis, Natural Language Processing, Computer Vision	Accelerated product development, improved consumer satisfaction, optimized product formulation, enhanced market research	Handling subjective sensory data, addressing cultural differences in food preferences, developing interpretable models for consumer behavior, ensuring data privacy in consumer research	Xu <i>et al.</i> , 2024; Fernandes and DMello, 2025

**Table 2 (continued):**

Sector/ Application	Specific AI Applications and Examples	Key Technologies/ Methods	Benefits/ Outcomes	Detailed Challenges/ Research Gaps	References
Food Processing Optimization	Process control, yield optimization, energy efficiency, quality control, predictive maintenance, automated sanitation, real time process monitoring	AI, Machine Learning, IoT, Robotics, Computer Vision, Process Modeling, Predictive Analytics	Reduced operational costs, improved product consistency, increased production efficiency, optimized resource utilization, minimized downtime	Integrating AI into existing food processing systems, ensuring real-time data processing, addressing cybersecurity risks, handling the complexity of biological processes, ensuring regulatory compliance	Kılınç <i>et al.</i> , 2023a; Kılınç <i>et al.</i> , 2023b; Kılınç <i>et al.</i> , 2024a; Kılınç <i>et al.</i> , 2024b
Food Production and Logistics	Demand forecasting, inventory optimization, supply chain monitoring, logistics optimization, warehouse management, distribution route optimization	AI, Machine Learning, Data Mining, Predictive Analytics, Optimization Algorithms, IoT, Blockchain	Reduced costs, improved efficiency, optimized inventory levels, enhanced supply chain transparency, reduced waste	Data integration across complex supply chain networks, real-time data processing, dynamic modeling for logistics optimization, data privacy and security, regulatory frameworks for AI in supply chains	Kaushal <i>et al.</i> , 2024; Zhang <i>et al.</i> , 2024; Niu <i>et al.</i> , 2024; Grira <i>et al.</i> , 2025; Malik <i>et al.</i> , 2024;
Food Safety and Regulatory Compliance	Food safety audits, regulatory compliance monitoring, risk assessment, document management, traceability, fraud detection	AI, Machine Learning, Natural Language Processing, Computer Vision, Blockchain, Data Analytics, IoT	Enhanced food safety, reduced regulatory violations, improved traceability, reduced food fraud, automated audits	Processing complex regulatory data, real-time compliance monitoring, integration of food safety data, regulatory frameworks for AI-driven audits, validation of AI models	Das <i>et al.</i> , 2025; Yang <i>et al.</i> , 2024
Food Marketing and Consumer Behavior	Consumer behavior analysis, personalized marketing, product recommendations, sentiment analysis, social media analysis, market research, price optimization	AI, Machine Learning, Natural Language Processing, Data Mining, Recommender Systems, Sentiment Analysis, Social Media Analytics	Improved customer satisfaction, increased sales, optimized marketing campaigns, enhanced market research, personalized consumer experiences	Processing complex consumer behavior data, data privacy for personalized marketing, real-time analysis of consumer sentiment, ethical considerations for AI-driven marketing, validation of AI models	Xu <i>et al.</i> , 2024; Fernandes and DMello, 2025

Table 2 (continued):

Sector/ Application	Specific AI Applications and Examples	Key Technologies/ Methods	Benefits/ Outcomes	Detailed Challenges/ Research Gaps	References
AI-Driven Food Product Development	New product formulation, flavor profile analysis, texture analysis, shelf-life prediction, consumer preference prediction, sensory analysis, ingredient optimization	AI, Machine Learning, Deep Learning, Sensory Data Analysis, Natural Language Processing, Computer Vision	Accelerated product development, improved product quality, optimized product formulation, enhanced consumer satisfaction, reduced waste	Processing subjective sensory data, addressing cultural differences in food preferences, developing interpretable models for consumer behavior, ensuring data privacy in consumer research	Xu <i>et al.</i> , 2024
AI-Enabled Education and Training	Food science and engineering education, virtual labs, personalized learning, automated assessment, virtual reality (VR) and augmented reality (AR) applications	AI, Machine Learning, Natural Language Processing, Virtual Reality, Augmented Reality, Personalized Learning Systems	Improved learning outcomes, increased student engagement, personalized learning experiences, reduced training costs, enhanced accessibility	Modeling complex food science concepts, virtual labs replicating real-world experiences, data privacy for personalized learning, ethical considerations for AI-driven education, validation of AI models	Rokhva <i>et al.</i> , 2024
AI in Food Service Operations	Automated order taking, kitchen automation, personalized menu recommendations, inventory management, customer behavior analysis, delivery route optimization, virtual assistants	AI, Machine Learning, Robotics, Natural Language Processing, Computer Vision, Recommender Systems, Location-Based Services	Improved operational efficiency, personalized customer experiences, reduced wait times, optimized inventory management, enhanced delivery services	Addressing variability in customer preferences, handling real-time order processing, ensuring data privacy in customer interactions, integrating AI with existing restaurant systems, managing automation costs	Rokhva <i>et al.</i> , 2024
Sustainable Food Systems	Resource optimization, waste reduction, carbon footprint monitoring, sustainable sourcing, alternative protein development, lifecycle assessment	AI, Machine Learning, IoT, Remote Sensing, Life Cycle Assessment tools, Optimization algorithms	Reduced environmental impact, improved resource efficiency, enhanced sustainability, optimized supply chains, promoted circular economy	Integration of diverse sustainability data, modeling complex environmental impacts, developing scalable solutions, ensuring ethical AI implementation, validating sustainability claims	Zatsu <i>et al.</i> , 2024; Nath <i>et al.</i> , 2024; Esmacily <i>et al.</i> , 2024

**Table 2 (continued):**

Sector/ Application	Specific AI Applications and Examples	Key Technologies/ Methods	Benefits/ Outcomes	Detailed Challenges/ Research Gaps	References
Food Accessibility and Security	Yield prediction, resource allocation, distribution optimization, early warning systems for food shortages, personalized dietary advice for vulnerable populations	AI, Machine Learning, Predictive Analytics, Remote Sensing, Geographic Information Systems (GIS), Mobile Applications	Improved food security, optimized resource distribution, reduced hunger, enhanced resilience, personalized nutrition guidance	Data availability in remote areas, addressing socio-economic factors impacting food access, developing culturally sensitive solutions, ensuring equitable access to technology, validating AI models	Sharma <i>et al.</i> , 2022
Smart Packaging and Traceability	Real-time freshness monitoring, temperature tracking, anti-counterfeiting, QR code analysis, dynamic shelf-life prediction, blockchain traceability, smart labels	AI, IoT, Blockchain, Sensors, Computer Vision, Data Analytics, Cloud Computing	Enhanced food safety, improved supply chain transparency, reduced food waste, increased consumer confidence, real-time product tracking	Ensuring data integrity in complex supply chains, addressing the cost of smart packaging technologies, handling data security and privacy, integrating diverse data sources, ensuring interoperability between systems	Yang <i>et al.</i> , 2024
Restaurant and Food Service	Automated order taking, kitchen automation, personalized menu recommendations, inventory management, customer behavior analysis, delivery route optimization	AI, Machine Learning, Robotics, Natural Language Processing, Computer Vision, Recommender Systems, Location-Based Services	Improved operational efficiency, personalized customer experience, reduced wait times, optimized inventory management, enhanced delivery services	Addressing the variability of customer preferences, handling real-time order processing, ensuring data privacy in customer interactions, integrating AI into existing restaurant systems, managing the cost of automation	Rokhva <i>et al.</i> , 2024

## Conclusion

The integration of AI, CV, and the IoT into fisheries and agricultural management represents a transformative paradigm, significantly enhancing precision, efficiency, safety, traceability, and quality control through sophisticated algorithms that demonstrate high fidelity in pathogen detection and product freshness

assessment. This technological convergence offers long-term economic efficiencies compared to conventional experimental methodologies, mitigates human-induced errors, and facilitates the expedited acquisition of robust and reliable results, thereby fortifying food safety for consumers and contributing to sustainable practices through waste reduction.

Furthermore, the incorporation of blockchain technology provides comprehensive transparency and bolsters consumer trust across the fisheries, aquaculture, and agriculture sectors. Nevertheless, the widespread adoption of these technologies is currently constrained by critical challenges, including the imperative for rigorous data standardization across production processes, the necessity for robust big data and data analytics infrastructure, the requirement for more extensive scientific validation to fully realize the potential of AI applications, substantial initial capital outlay, and ongoing ethical deliberations. Notwithstanding these impediments, it is anticipated that AI will become an integral component of daily operations for both producers and consumers in the foreseeable future, with integration into smartphone applications enabling consumers to trace the entire provenance of food products, perform freshness analyses via CV and machine learning, and instantaneously determine shelf life, signifying a revolutionary advancement in the food industry towards the attainment of sustainability goals (SDGs), including zero waste and ultimately, the eradication of hunger (SDG 2).

### Conflicts of interest

The authors declared that they have no conflict of interest

### References

**Alhasan, M. and Hasaneen, M., 2021.** Digital imaging, technologies and artificial intelligence applications during COVID-19 pandemic. *Computerized*

*Medical Imaging and Graphics*, 91, 101933.

DOI:10.1016/j.compmedimag.2021.101933

**Ali, A.M.A. and Alrobaian, M.M., 2024.** Strengths and weaknesses of current and future prospects of artificial intelligence-mounted technologies applied in the development of pharmaceutical products and services. *Saudi Pharmaceutical Journal*, 32(5), 102043.

DOI:10.1016/j.jsps.2024.102043

**Almoselhy, R.I.M. and Usmani, A., 2024.** AI in food science: Exploring core elements, challenges, and future directions. *Journal of Microbiology & Biotechnology*, 9(4), 000313.

DOI:10.23880/oajmb-16000313

**Amore, A. and Philip, S., 2023.** Artificial intelligence in food biotechnology: Trends and perspectives. *Frontiers in Industrial Microbiology*, 1, 1255505.

DOI:10.3389/finmi.2023.1255505

**Assaf, S., 2024.** Food database meets artificial intelligence: A new method for personalized patient eating plans. *Journal of the Academy of Nutrition and Dietetics*, 124(10), A70.

DOI:10.1016/j.jand.2024.07.065

**Bagnulo, E., Strocchi, G., Bicchi, C. and Liberto, E., 2024.** Industrial food quality and consumer choice: Artificial intelligence-based tools in the chemistry of sensory notes in comfort foods (coffee, cocoa and tea). *Trends in Food Science & Technology*, 147, 104415.

DOI:10.1016/j.tifs.2024.104415

**Barthwal, R., Kathuria, D., Joshi, S., Kaler, R.S.S. and Singh, N., 2024.** New trends in the development and

- application of artificial intelligence in food processing. *Innovative Food Science & Emerging Technologies*, 92, 103600.  
DOI:10.1016/j.ifset.2024.103600
- Beck, K.L., Haiminen, N., Agarwal, A., Carrieri, A.P., Madgwick, M., Kelly, J., Wiedmann, M. and Ganda, E., 2024.** Development and evaluation of statistical and artificial intelligence approaches with microbial shotgun metagenomics data as an untargeted screening tool for use in food production. *mSystems*, 9(11), e00840-24. DOI:10.1128/msystems.00840-24
- Bhagat, S.K., Tung, T.M. and Yaseen, Z.M., 2020.** Development of artificial intelligence for modeling wastewater heavy metal removal: State of the art, application assessment and possible future research. *Journal of Cleaner Production*, 250, 119473. DOI:10.1016/j.jclepro.2019.119473
- Caratti, A., Squara, S., Bicchi, C., Liberto, E., Vincenti, M., Reichenbach, S.E., Tao, Q., Geschwender, D., Alladio, E. and Cordero, C., 2024.** Boosting comprehensive two-dimensional chromatography with artificial intelligence: Application to food-omics. *TrAC Trends in Analytical Chemistry*, 174, 117669. DOI:10.1016/j.trac.2024.117669
- Chang, J., Wang, H., Su, W., He, X. and Tan, M., 2024.** Artificial intelligence in food bioactive peptides screening: Recent advances and future prospects. *Trends in Food Science & Technology*, In Press. DOI:10.1016/j.tifs.2024.104845
- Chiang, A.L. and Hong, H., 2025.** The role of industry to grow clinical artificial intelligence applications in gastroenterology and endoscopy. *Gastrointestinal Endoscopy Clinics of North America*, 35(2):485-501. DOI:10.1016/j.giec.2024.12.002
- Chong, J.W.R., Khoo, K.S., Chew, K.W., Ting, H.Y., Iwamoto, K., Ruan, R., Ma, Z. and Show, P.L., 2024.** Artificial intelligence-driven microalgae autotrophic batch cultivation: A comparative study of machine and deep learning-based image classification models. *Algal Research*, 79, 103400. DOI:10.1016/j.algal.2024.103400
- Chotwanvirat, P., Prachansuwan, A., Sridonpai, P. and Kriengsinyos, W., 2024.** Automated artificial intelligence-based Thai food dietary assessment system: Development and validation. *Current Developments in Nutrition*, 8(5), 102154. DOI:10.1016/j.cdnut.2024.102154
- Choudhary, B., Das, A. and Choudhary, V., 2025.** Application of artificial intelligence (AI) in aquaculture/fisheries: Microbial disease identification and diagnosis. *Methods in Microbiology*, 56, 313–350. DOI:10.1016/bs.mim.2024.12.003
- Cortes, C. and Vapnik, V., 1995.** Support vector networks. *Machine Learning*, 20, 273–297.
- Das, P., Altemimi, A.B., Nath, P.C., Katyal, M., Kesavan, R.K., Rustagi, S., Panda, J., Avula, S.K., Nayak, P.K. and Mohanta, Y.K., 2025.** Recent advances on artificial intelligence-based approaches for food adulteration and fraud detection in the food industry:

- Challenges and opportunities. *Food Chemistry*, 468, 142439. DOI:10.1016/j.foodchem.2024.142439
- Demirci, M., 2019.** Destek vektör makineleri ve M5 karar ağacı yöntemleri kullanılarak yağış-akış ilişkisinin tahmini. *DÜMF Mühendislik Dergisi*, 10(3), 1113–1124. DOI:10.24012/dumf.525658 (In Turkish)
- Deng, L. and Yu, D., 2014.** Deep learning: Methods and applications. *Foundations and Trends in Signal Processing*, 7(3–4), 197–387. DOI:10.1561/20000000039
- Duda, R.O. and Hart, P.E., 1973.** Pattern classification and scene analysis. *John Wiley and Sons*, Singapore, pp 253.
- Esmaily, R., Razavi, M.A. and Razavi, S.H., 2024.** A step forward in food science, technology and industry using artificial intelligence. *Trends in Food Science & Technology*, 143, 104286. DOI:10.1016/j.tifs.2023.104286
- Feng, Y., Li, X., Zhang, Y. and Xie, T., 2023.** Detection of Atlantic salmon residues based on computer vision. *Journal of Food Engineering*, 358, 111658. DOI:10.1016/j.jfoodeng.2023.111658
- Feng, Y., Soni, A., Brightwell, G., Reis, M.M., Wang, Z., Wang, J., Wu, Q. and Ding, Y., 2024.** The potential new microbial hazard monitoring tool in food safety: Integration of metabolomics and artificial intelligence. *Trends in Food Science & Technology*, 149, 104555. DOI:10.1016/j.tifs.2024.104555
- Fernandes, S. and DMello, A., 2025.** Artificial intelligence in the aquaculture industry: Current state, challenges and future directions. *Aquaculture*, 598, 742048. DOI:10.1016/j.aquaculture.2024.742048
- Frank, B., 2024.** Consumer preferences for artificial intelligence-enhanced products: Differences across consumer segments, product types, and countries. *Technological Forecasting and Social Change*, 209, 123774. DOI:10.1016/j.techfore.2024.123774
- Gao, Z., Huang, J., Chen, J., Shao, T., Ni, H. and Cai, H., 2024.** Deep transfer learning based computer vision for real time harvest period classification and impurity detection of *Porphyra haitnensis*. *Aquaculture International*, 32, 5171-5198. DOI:10.1007/s10499-024-01422-6
- Genç, İ. Y., Gürfidan, R. and Yiğit, T., 2025.** Quality prediction of sea bream (*Sparus Aurata*) by Deep learning algorithms and explainable artificial intelligence. *Food Chemistry*, 143150. In press. DOI:10.1016/j.foodchem.2025.143150
- Gladju, J., Kamalam, B. S. and Kanagaraj, A., 2022.** Applications of data mining and machine learning framework in aquaculture and fisheries: A review. *Smart Agricultural Technology*, 2, 100061. DOI:10.1016/j.atech.2022.100061
- Goodfellow, I., Bengio, Y. and Courville, A., 2016.** Deep learning. *The MIT Press*, Cambridge, Massachusetts, USA. pp 800.
- Goulart, F., Anna, V. S., Almlı, V. L. and Maschio, G. T., 2025.** Can children and artificial intelligence be sources of ideas for school meal preparations based on whole food utilization? *Food Quality*

- and Preference*, 123, 105349.  
DOI:10.1016/j.foodqual.2024.105349
- Goyache, F., Bahamonde, A., Alonso, J., Lopez, S., Coz, J. J., Quevedo, J. R., Ranilla, J., Luaces, O., Alvarez, I., Royo, L. J. and Diez, J., 2001.** The usefulness of artificial intelligence techniques to assess subjective quality of products in the food industry. *Trends in Food Science & Technology*, 12(10), 370-381. DOI:10.1016/S0924-2244(02)00010-9
- Griira, S., Mozumder, M. S., Mourad, A. H. I., Ramadan, M., Khalifeh, H.A. and Alkhedher, M., 2025.** 3D bioprinting of natural materials and their AI-Enhanced printability: A review. *Bioprinting*, 46, e00385. DOI:10.1016/j.bprint.2025.e00385
- Guo, P., Wang, Y., Moghaddamfard, P., Meng, W., Wu, S. and Bao, Y., 2024.** Artificial intelligence-empowered collection and characterization of microplastics: A review. *Journal of Hazardous Materials*, 471, 134405. DOI:10.1016/j.jhazmat.2024.134405
- Guo, Y., Liu, Y., Oerlemans, A., Lao, S., Wu, S. and Lew, M. S., 2016.** Deep learning for visual understanding: A review. *Neurocomputing*, 187, 27-48. DOI:10.1016/j.neucom.2015.09.116
- Hashemi, S., Vosough, P., Taghizadeh, S. and Savardashtaki, A., 2024.** Therapeutic peptide development revolutionized: Harnessing the power of artificial intelligence for drug discovery. *Heliyon*, 10(22), e40265. DOI:10.1016/j.heliyon.2024.e40265
- Hassoun, A., Dankar, I., Bhat, Z. and Bouzembrak, Y., 2024.** Unveiling the relationship between food unit operations and food industry 4.0: A short review. *Heliyon*, 10(20), e39388. DOI:10.1016/j.heliyon.2024.e39388
- Hinton, G.E., Osindero, S. and Teh, Y.W., 2006.** A fast learning algorithm for deep belief nets. *Neural Computation*, 18(7), 1527-1554. DOI:10.1162/neco.2006.18.7.1527
- Hu, B., Dai, Y., Zhou, H., Sun, Y., Yu, H., Dai, Y., Wang, M., Ergu, D. and Zhou, P., 2024.** Using artificial intelligence to rapidly identify microplastics pollution and predict microplastics environmental behaviors. *Journal of Hazardous Materials*, 474, 134865. DOI:10.1016/j.jhazmat.2024.134865
- Hua, S. and Sun, Z., 2001.** A Novel Method of Protein Secondary Structure Prediction with High Segment Overlap Measure: Support Vector Machine Approach. *Journal of Molecular Biology*, 308(3), 397-407. DOI:10.1006/jmbi.2001.4580
- Huang, J., Zhang, M., Mujumdar, A. S. and Li, C., 2025.** AI-based processing of future prepared foods: Progress and prospects. *Food Research International*, 201, 115675. DOI:10.1016/j.foodres.2025.115675
- Hwa, L. S. and Chuan, L. T., 2024.** A Brief Review of Artificial Intelligence Robotics in Food Industry. *Procedia Computer Science*, 232, 1694-1700. DOI:10.1016/j.procs.2024.01.167
- Jadhav, H. B., Alaskar, K., Desai, V., Sane, A., Choudhary, P., Annapure, U., Uddin, J. and Nayik, G. A. 2025.** Transformative impact: Artificial intelligence in the evolving landscape of processed food-A concise review focusing on some food processing

- sectors. *Food Control*, 167, 110803. DOI:10.1016/j.foodcont.2024.110803
- Kandilci, M., Yakıcı, G. and Kayar, M. B., 2024.** Artificial Intelligence and Microbiology. *Experimental and Applied Medical Science*, 5(2), 119-128. DOI:10.46871/eams.14587
- Karanth, S., Benefo, E. O., Patra, D. and Pradhan, A. K., 2023.** Importance of artificial intelligence in evaluating climate change and food safety risk. *Journal of Agriculture and Food Research*, 11, 100485. DOI:10.1016/j.jafr.2022.100485
- Kaushal, S., Tammineni, D. K., Rana, P., Sharma, M., Sridhar, K. and Chen, H. H., 2024.** Computer vision and deep learning-based approaches for detection of food nutrients/nutrition: New insights and advances. *Trends in Food Science & Technology*, 146, 104408. DOI:10.1016/j.tifs.2024.104408
- Khokher, M. R., Little, L. R., Tuck, G. N., Smith, D. V., Qiao, M., Devine, C., O'Neill, H., Pogonoski, J. J., Arangio, R. and Wang, D., 2021.** Early lessons in deploying cameras and artificial intelligence technology for fisheries catch monitoring: where machine learning meets commercial fishing. *Canadian Journal of Fisheries and Aquatic Sciences*, 79(2), 257-266. DOI:10.1139/cjfas-2020-0446
- Kılınç, B., Kılınç, I., and Takma, Ç., 2022.** Mathematical Models for Pathogenic Bacteria Risk and Control Assessments of Seafood Products. In: Akar T. (eds) International Research in Agriculture, Forestry and Aquaculture Sciences, Serüven Publishing, Türkiye. pp 57-83.
- Kılınç, B., Takma, C. and Kılınç, I. 2023a.** Deep Learning Applications on Marine Applications on Marine Environment and Products. In: Doğanlar B. and Küçüker E. (eds) International Theory, Research and Reviews in Agriculture, Forestry and Aquaculture Sciences, Serüven Publishing, Türkiye. pp 155-177.
- Kılınç, B., Kılınç, I., Takma, Ç. and Gevrekçi, Y., 2023b.** Recent Developments on Seafood Evaluation Using Machine Learning Models. In: Takma, Ç., Gevrekçi, Y. and Hızlı H. (eds) Tarımsal Alanlarda İstatistiksel Analizler, Holistence Publications, Türkiye. pp 147-176.
- Kılınç, B., Kılınç, I., Takma, Ç. and Gevrekçi, Y., 2024a.** Review: The applications of Fuzzy Logic models on food and marine food products. *Journal of Food Safety and Food Quality*, 75(2), 35-64. DOI: 10.31083/0003-925X-75-52
- Kılınç, I., Kılınç, B. and Takma, Ç., 2022.** The Predictive Models Used For Bacterial Growth and Shelf-Life of Fishery Products During Storage. In: Kop, A. and Karataş, B. (eds) Advances In Aquaculture and Fisheries Research, Iksad Publications, Türkiye. pp. 59-86.
- Kılınç, I. 2024.** The place of Industry 4.0 artificial intelligence applications in the production sector: Effects on food safety and quality. In: 1st International Data Analytics Congress. Izmir Katip Celebi University, Türkiye. pp 8-9.
- Kılınç, I., Kılınç, B., Gevrekçi, Y. and Takma, Ç., 2024b.** Artificial neural networks models used for fishery products. *Journal of Food Safety and*

- Food Quality*, 75(1), 24-34.  
DOI:10.53194/0003-925X-75-24
- Kutyauripo, I., Rushambwa, M. and Chiwazi, L., 2023.** Artificial intelligence applications in the agrifood sectors. *Journal of Agriculture and Food Research*, 11, 100502.  
DOI:10.1016/j.jafr.2023.100502
- Lee, C. C., Yan, J. and Wang, F., 2024.** Impact of population aging on food security in the context of artificial intelligence: Evidence from China. *Technological Forecasting and Social Change*, 199, 123062.  
DOI:10.1016/j.techfore.2023.123062
- Li, H., Xu, H., Li, Y. and Li, X., 2024.** Application of artificial intelligence (AI)-enhanced biochemical sensing in molecular diagnosis and imaging analysis: Advancing and challenges. *TrAC Trends in Analytical Chemistry*, 174, 117700.  
DOI:10.1016/j.trac.2024.117700
- Liu, Q., Li, S., Li, Z., Zou, C., Feng, S., Song, J., Zhang, J. and Li, X., 2025.** A novel multimodal nano-sensor detection system based on artificial intelligence and two-dimensional Mxenes for Ochratoxin A in food. *Food Control*, 170, 111055.  
DOI:10.1016/j.foodcont.2024.111055
- Liu, Z., Zhou, Y., Wang, H., Liu, C. and Wang, L., 2024.** Recent advances in understanding the fitness and survival mechanisms of *Vibrio parahaemolyticus*. *International Journal of Food Microbiology*, 417, 110691.  
DOI:10.1016/j.ijfoodmicro.2024.110691
- Lu, T., Yu, F., Han, B., Guo, J., Liu, K. and He, S., 2023.** An Intelligent Method for Predicting Pacific Oyster (*Crassostrea gigas*) Freshness Using Deep Learning Fused with Malondialdehyde and Total Sulfhydryl Groups Information. *Foods*, 12(19), 3616. DOI:10.3390/foods12193616
- Lysova, N., Solari, F. and Montanari, R., 2025.** Investigating Research Trends in Computer Vision for Food Quality Control: A Bibliometric Approach. *Procedia Computer Science*, 253, 1923-1932. DOI:10.1016/j.procs.2025.01.254
- Ma, S., Zhang, M., Sun, W., Gao, Y., Jing, M., Gao, L. and Wu, Z., 2025.** Artificial intelligence and medical-engineering integration in diabetes management: Advances, opportunities, and challenges. *Healthcare and Rehabilitation*, 1(1), 100006.  
DOI:10.1016/j.hcr.2024.100006
- Malik, S., Muhammed, K. and Waheed, Y., 2024.** Artificial intelligence and industrial applications-A revolution in modern industries. *Ain Shams Engineering Journal*, 15(9), 102886.  
DOI:10.1016/j.asej.2024.102886
- Manning, L., Brewer, S., Craigon, P. J., Frey, J., Gutierrez, A., Jacobs, N., Kanza, S., Munday, S., Sacks, J. and Pearson, S., 2022.** Artificial intelligence and ethics within the food sector: Developing a common language for technology adoption across the supply chain. *Trends in Food Science & Technology*, 125, 33-42.  
DOI:10.1016/j.tifs.2022.04.025
- Martnez, C. H., Cosana, G. Z. and Garcia-Gimeno, R. M., 2005.** Application of Artificial Intelligence to Predictive Microbiology. In G. V. Barbosa-Canovas, M. S. Tapia, & M. P.

- Cano (Eds.), *Novel Food Processing Technologies* (pp. 609-628). CRC Press. ISBN:9780824753337
- Medina, V.Y., 2023.** Predictive Microbiology and Machine Learning by Optimization Productive Process: Meta analysis. *Acta Scientific Microbiology*, 6(2), 54-66.
- Mir, A. M., Khan, M. A. A., Banik, B. K., Hasnain, S. M., Alzayer, L., Andrews, K. and Abba, S. I., 2025.** Microplastics in food products: Prevalence, artificial intelligence based detection, and potential health impacts on humans. *Emerging Contaminants*, 11(2), 100477. DOI:10.1016/j.emcon.2025.100477
- Mohseni, P. and Ghorbani, A. 2024.** Exploring the synergy of artificial intelligence in microbiology: Advancements, challenges, and future prospects. *Computational and Structural Biotechnology Reports*, 1, 100005. DOI:10.1016/j.csbr.2024.100005
- Moulahoum, H. and Ghorbanizamani, F., 2024.** Navigating the development of silver nanoparticles based food analysis through the power of artificial intelligence. *Food Chemistry*, 445, 138800. DOI:10.1016/j.foodchem.2024.138800
- Nath, P.C., Mishra, A.K., Sharma, R., Bhunia, B., Mishra, B., Tiwari, A., Nayak, P.K., Sharma, M., Bruyan, T., Kaushal, S., Mohanta, Y.K. and Sridhar, K., 2024.** Recent advances in artificial intelligence towards the sustainable future of agri-food industry. *Food Chemistry*, 447, 138945. DOI:10.1016/j.foodchem.2024.138945
- Nawaz, A., Afzal, A., Khatibi, A., Shankar, A., Madan, H., Faisal, H. S., Shahbaz, A., Usman, I., Zulfiqar, N., Saeed, F., Ahmed, A., Imran, A., Afzaal, M., Karni, A., Ahmed, F., Akram, N., Rasheed, M. and Islam, F., 2025.** Role of artificial intelligence in halal authentication and traceability: A concurrent review. *Food Control*, 169, 111003. DOI:10.1016/j.foodcont.2024.111003
- Niu, H., Zhang, M., Yu, Q. and Liu, Y., 2024.** Status and trends of artificial intelligence in the R & D of future fruit & vegetable juice. *Innovative Food Science & Emerging Technologies*, 97, 103796. DOI:10.1016/j.ifset.2024.103796
- Nunes, C. A., Ribeiro, M. N., Carvalho, T. C., Ferreira, D. D., Oliveira, L. L. and Pinheiro, A. C. M., 2023.** Artificial intelligence in sensory and consumer studies of food products. *Current Opinion in Food Science*, 50, 101002. DOI:10.1016/j.cofs.2023.101002
- O'Shea, N., Greene, D. and Fenelon, M.A., 2024.** Artificial Intelligence in Food Safety. In: *Encyclopedia of Food Safety* (Second Edition). Elsevier, Amsterdam, Netherlands. pp 178-184.
- Othman, S., Mavani, N.R., Hussain, M.A., Rahman, N.A. and Ali, J.M., 2023.** Artificial intelligence-based techniques for adulteration and defect detections in food and agricultural industry: A review. *Journal of Agriculture and Food Research*, 12, 100590. DOI:10.1016/j.jafr.2023.100590
- Pajila, P. B., Sheena, B. G., Gayathri, A., Aswini, J. and Nalini, M. 2023.** A

- comprehensive survey on Naive Bayes algorithm: advantages, limitations and applications. In: 4th International conference on smart electronics and communication (ICOSEC), Trichy, India. pp 1228–1234.
- Pane, R.A., Mubarak, S.M. and Huda, N.S., 2018.** A multi-label classification on topics of quranic verses in english translation using multinomial naive bayes. In: 6th International Conference on Information and Communication Technology (ICoICT), Bandung, Indonesia. pp 481-484.
- Pantanowitz, L., Hanna, M., Pantanowitz, J., Lennerz, J., Henricks, W. H., Shen, P., Quinn, B., Bennet, S. and Rashidi, H. H., 2024.** Regulatory Aspects of Artificial Intelligence and Machine Learning. *Modern Pathology*, 37(12), 100609. DOI:10.1016/j.modpat.2024.100609
- Paygude, P., Gayakwad, M., Wategaonkar, D., Pawar, R., Pujeri, R. and Joshi, R., 2024.** Dried fish dataset for Indian seafood: A machine learning application. *Data in Brief*, 55, 110563. DOI:10.1016/j.dib.2024.110563
- Ramandani, A. A., Chong, J. W. R., Srinuanpan, S., Lim, J. W., Jiang, J. J. and Khoo, K. S., 2025.** Artificial intelligence-driven prediction models for the cultivation of *Chlorella vulgaris* FSP-E in food waste culture medium: A comparative analysis and validation of models. *Algal Research*, 103905. DOI:10.1016/j.algal.2025.103935
- Rather, M. A., Ahmad, I., Shah, A., Hajam, Y. A., Amin, A., Khursheed, S., Ahmad, I. and Rasool, S., 2024.** Exploring opportunities of Artificial Intelligence in aquaculture to meet increasing food demand. *Food Chemistry* X, 22, 101309. DOI:10.1016/j.fochx.2024.101309
- Rochva, S., Teimourpour, B. and Soltani, A. H., 2024.** Computer vision in the food industry: Accurate, real-time, and automatic food recognition with pre trained Mobile Net V2. *Food and Humanity*, 3, 100378. DOI:10.1016/j.foohum.2024.100378
- Schmidhuber, J., 2015.** Deep learning in neural networks: An overview. *Neural Networks*, 61, 85-117. DOI:10.1016/j.neunet.2014.09.003
- Shamtej, S.R.B.S., Jacob, S.G.B.A. and Ronald, A.N.M.D., 2025.** The future of Food and Drug Administration regulation on artificial intelligence-enabled medical devices: an orthopedic surgeon's guide. *Journal of Shoulder and Elbow Surgery*, 34(1), 260-264. DOI:10.1016/j.jse.2024.08.008
- Sharifmousavi, M., Kayvanfar, V. and Baldacci, R., 2024.** Distributed Artificial Intelligence Application in Agri-food Supply Chains 4.0. *Procedia Computer Science*, 232, 211-220. DOI:10.1016/j.procs.2024.01.021
- Sharma, P., Vimal, A., Vishvakarma, R., Kumar, P., Vandenberghe, L. S., Gaur, V. K. and Varjani, S., 2022.** Deciphering the black box of omics approaches and artificial intelligence in food waste transformation and mitigation. *International Journal of Food Microbiology*, 372, 109691. DOI:10.1016/j.ijfoodmicro.2022.109691

- Sherbini, A.E., Rosenson, R.S., Rifai, M.A., Virk, H.U.H., Wang, Z., Virani, S., Glicksberg, B.S., Lavie, C.J. and Krittanawong, C., 2024.** Artificial intelligence in preventive cardiology. *Progress in Cardiovascular Diseases*, 84, 76-89. DOI:10.1016/j.pcad.2024.03.002
- Singh, S.K., Jha, R., Pandey, S., Mohan, C., Ghosh, S.C., Singh, S.K., Kumari, S. and Singh, A., 2025.** Artificial intelligence-based tools for next-generation seed quality analysis. *Crop Design*, 4(1), 100094. DOI:10.1016/j.crope.2024.100094
- Singh, Y., Kaur, A. and Malhora, R., 2009.** Application of Support Vector Machine to Predict Fault Prone Classes. *SIGSOFT Software Engineering Notes*, 34(1), 1-6. DOI:10.1145/1457516.1457529
- Srinivasan, A., Gupta, A. and Narayanamurthy, V., 2025.** A comprehensive review of AI-based collagen valorization: Recent trends, innovations in extraction, and applications. *Green Analytical Chemistry*, 12, 100212. DOI:10.1016/j.greeac.2025.100212
- Sriprateep, K., Pitakaso, R., Khonjun, S., Luesak, P., Jutagate, A., Kaewta, C., Srichok, T., Kosacka-Olejnik, M. and Matitopanum, S., 2025.** Optimizing Nile Tilapia growth and production costs in earthen ponds using multi-objective adaptive artificial intelligence systems. *Aquaculture Reports*, 102716. DOI:10.1016/j.aqrep.2025.102716
- Subramanian, R. S. and Prabha, D., 2022.** Ensemble variable selection for Naive Bayes to improve customer behaviour analysis. *Computer Systems Science & Engineering*, 41(1), 339-355. DOI:10.32604/csse.2022.020043
- Şeker, A., Diri, B. and Balık, H., 2017.** Derin Öğrenme Yöntemleri ve Uygulamaları Hakkında Bir İnceleme. *Gazi Journal of Engineering Sciences*, 3(3), 47-64. (In Turkish)
- Thapa, A., Nishad, S., Biswas, D. and Roy, S., 2023.** A comprehensive review on artificial intelligence assisted technologies in food industry. *Food Bioscience*, 56, 103231. DOI:10.1016/j.fbio.2023.103231
- Thibault, B., Zeynoddin, M., Bonakdari, H., Ratti, C. and Khalloufi, S., 2024.** Assessment of artificial intelligence for predicting porosity of dehydrated food products. *Computers and Electronics in Agriculture*, 221, 108934. DOI:10.1016/j.compag.2024.108934
- Ubina, N.A., Lan, H.Y., Cheng, S.C., Chang, C.C., Lin, S.S., Zhang, K.X., Lu, H.Y., Chen, C.Y. and Hsieh, Y.Z., 2023.** Digital twin-based intelligent fish farming with Artificial Intelligence Internet of Things (AIoT). *Smart Agricultural Technology*, 5, 100285. DOI:10.1016/j.atech.2023.100285
- Vapnik, V., 1995.** The nature of statistical learning theory. *Springer*, New York, USA. pp 188.
- Vapnik, V., Golowich, S. and Smola, A., 1997.** Support vector method for function approximation, regression estimation, and signal processing. In: *Advances in Neural Information Processing Systems*, The MIT Press. Cambridge, Massachusetts, USA. pp 281-287.

- Welch, H., Ames, R.T., Kolla, N., Kroodsma, D.A., Marsaglia, L., Russo, T., Watson, J.T. and Hazen, E.L., 2024.** Harnessing AI to map global fishing vessel activity. *One Earth*, 7(10), 1685-1691.  
DOI:10.1016/j.oneear.2024.09.009
- Widyawati, D., Faradibah, A. and Belluano, P.L.L., 2023.** Comparison Analysis of Classification Model Performance in Lung Cancer Prediction Using Decision Tree, Naive Bayes, and Support Vector Machine. *Indonesian Journal of Data and Science*, 4(2), 78-86. DOI:10.56705/ijodas.v4i2.76
- Wu, X., Kumar, V., Quinlan, J. R., Ghosh, J., Yang, Q., Motoda, H., Mclachlan, G. J., Ng, A., Liu, B. and Yu, P. S., 2008.** Top 10 algorithms in data mining. *Knowledge and Information Systems*, 14(1), 1-37. DOI:10.1007/s10115-007-0114-2
- Xing, W. and Du, D., 2018.** Dropout Prediction in MOOCs: Using Deep Learning for Personalized Intervention. *Journal of Educational Computing Research*, 57(3), 547-570. DOI:10.1177/0735633118757015
- Xu, Q., Zhou, Y. and Wu, L., 2024.** Advancing tea detection with artificial intelligence: Strategies, progress, and future prospects. *Trends in Food Science & Technology*, 153, 104731. DOI:10.1016/j.tifs.2024.104731
- Yan, L., Zhang, B., Zhou, W., Hao, J., Shi, H., Wang, S., Shuang, S. and Shi, L., 2024.** An artificial intelligence handheld sensor for direct reading of nickel ion and ethylenediaminetetraacetic acid in food samples using ratiometric fluorescence cellulose paper microfluidic chip. *International Journal of Biological Macromolecules*, 279(Part 1), 135083. DOI:10.1016/j.ijbiomac.2024.135083
- Yang, T., Zhang, X., Yan, Y., Liu, Y., Lin, X. and Li, W., 2025.** Artificial intelligence-driven quantification of antibiotic-resistant Bacteria in food by color-encoded multiplex hydrogel digital LAMP. *Food Chemistry*, 468, 142304. DOI:10.1016/j.foodchem.2024.142304
- Yang, Y., Du, Y., Gupta, V. K., Ahmad, F., Amiri, H., Pan, J., Aghbashlo, M., Tabatabaei, M. and Rajaei, A., 2024.** Exploring blockchain and artificial intelligence in intelligent packaging to combat food fraud: A comprehensive review. *Food Packaging and Shelf Life*, 43, 101287. DOI:10.1016/j.fpsl.2024.101287
- Yasin, E. T., Özkan, İ. A. and Koklu, M., 2023.** Detection of fish freshness using artificial intelligence methods. *European Food Research and Technology*, 249, 1779-1790. DOI:10.1007/s00217-023-04271-4
- Yi, L., Wang, W., Diao, Y., Yi, S., Shang, Y., Ren, D., Ge, K. and Gu, Y., 2024.** Recent advances of artificial intelligence in quantitative analysis of food quality and safety indicators: A review. *TrAC Trends in Analytical Chemistry*, 180, 117944. DOI:10.1016/j.trac.2024.117944
- Yu, W., Ouyang, Z., Zhang, Y., Lu, Y., Wei, C., Tu, Y. and He, B., 2025.** Research progress on the artificial intelligence applications in food safety and quality management. *Trends in Food Science & Technology*, 156,

104855.  
DOI:10.1016/j.tifs.2024.104855
- Yuan, J., Ma, D., Yang, Y., Zhao, Y., Ren, H., Liu, X., Tan, M. and Li, K., 2025.** A review and prospects: Multi-omics and artificial intelligence-based approaches to understanding the effects of lactic acid bacteria and yeast interactions on fermented foods. *Innovative Food Science & Emerging Technologies*, 99, 103874. DOI:10.1016/j.ifset.2024.103874
- Zatsu, V., Shine, A.E., Tharakan, J.M., Peter, D., Ranganathan, T.V., Alotaibi, S.S., Mugabi, R., Muhsinah, A.B., Waseem, M. and Nayik, G.A., 2024.** Revolutionizing the food industry: The transformative power of artificial intelligence-a review. *Food Chemistry: X*, 24, 101867. DOI:10.1016/j.fochx.2024.101867
- Zhang, D.Y., Venkat, A., Khasawneh, H., Sali, R., Zhang, V. and Pei, Z., 2024.** Implementation of Digital Pathology and Artificial Intelligence in Routine Pathology Practice. *Laboratory Investigation*, 104(9), 102111. DOI:10.1016/j.labinv.2024.102111
- Zhang, H., Ding, Y., Niu, J. and Jung, S., 2024.** How artificial intelligence affects international industrial transfer — Evidence from industrial robot application. *Journal of Asian Economics*, 95, 101815. DOI:10.1016/j.asieco.2024.101815